

# PORTABLE SAWMILL

## FREEDOM RS18G

**PERFECT FOR THE DO-IT-YOURSELF**

### OPERATOR'S MANUAL

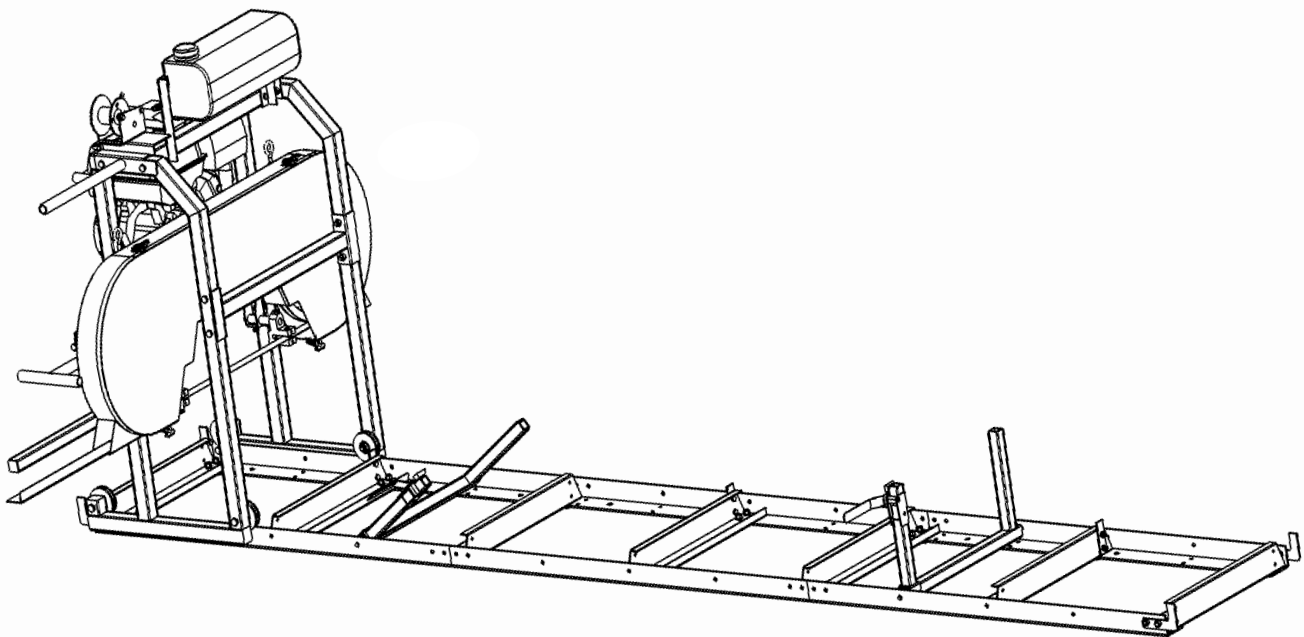

**WARNING:**  
Read carefully and understand all ASSEMBLY AND OPERATION INSTRUCTIONS before operating.  
Failure to follow the safety rules and other basic safety precautions may result in serious personal injury.

# TABLE OF CONTENTS

INTRODUCTION.....	2
TECHNICAL SPECIFICATIONS.....	3
GENERAL SAFETY RULES .....	4
GENERAL MAINTENANCE INFORMATION.....	9
SAWMILL ASSEMBLY INSTRUCTIONS.....	10
SAWMILL SET-UP PROCEDURES.....	23
BELT TENSION .....	23
BLADE TRACKING.....	25
BLADE GUIDE ADJUSTMENT .....	31
SAWMILL MAINTENANCE .....	33
BLADE TENSION.....	33
CHANGING THE BLADE .....	33
REPLACING BELTS.....	34
TROUBLE SHOOTING.....	36
PARTS LIST .....	39
PART DIAGRAMS .....	43
NOTES.....	44

# INTRODUCTION

RS18G FREEDOM PORTABLE SAWMILLS, THE MOST AFFORDABLE BUILD-IT-YOURSELF SAWMILLS.

Save money and assemble the band saw yourself.

Built for the handyman, farmer, woodland homesteader or outdoor fans.

This machine is designed for certain applications only. We strongly recommend that this machine not be modified and / or used for any application other than that for which it was designed. If you have questions about a particular application, **DO NOT** use the machine until you have contacted us to determine if it can or should be performed on the product.

## THERMAL VERSION



## WARNING:

It is essential to put oil (10W30) in the engine before first use.

## INTENDED USE

This sawmill is designed for sawing logs while the mill is firmly supported on the wood or ground.

## TECHNICAL SPECIFICATIONS

Every machine we produce is fitted with a name plate with its serial number. The number is also punched on the machine. An exact description of the machine model and serial number will facilitate rapid and effective replies from our after-sales service. All the models are identical machine except the model name, the following name plate is one example:

ITEM	DESCRIPTION
Gasoline Engine	7.0 HP
Maximum Log Diameter	18" (460mm)
Cutting capacity	460*170*2780mm (18"*6.7"*109")
Maximum Board Thickness	6.7" (170mm)
Blade Size	3050*32*0.9mm (120"*1-1/4"*0.035")
Weight	145kg

## CE LABEL

Portable Sawmill	
<b>Model</b>	RS18G
<b>Power</b>	7HP
<b>Serial No. :</b>	00001
<b>Date</b>	2022.4
<b>Blade size</b>	3050mmx32mm
<b>Weight</b>	145 kg
Yantai Rima Machinery Co., Ltd.	
Address: Room 1018-A2, No. 8Xiguan South Street, Zhifu District, Yantai City, Shandong Province 264001, P, R, China	
	

# GENERAL SAFETY RULES



## **WARNING!**

Read and understand all instructions. Failure to follow all instructions listed below may result in electric shock, fire and/or serious injury.



## **WARNING!**

The warnings, cautions, and instructions discussed in this instruction manual cannot cover all possible conditions or situations that could occur. It must be understood by the operator that common sense and caution are factors which cannot be built into this product, but must be supplied by the operator.



## **WARNING!**

Only operate the engine in a well ventilated area. Carbon Monoxide produced by the engine during use can kill. Do not use indoors, near windows or in other sheltered areas.

NOTE: All Federal and State laws and any regulation having jurisdiction covering the safety requirements for use of the machine take precedence over the statements in this manual. Users of this machine must adhere to such regulations.

# SAVE THESE INSTRUCTIONS

## WORK AREA

- **Keep work area clean**, free of clutter and well lit. Cluttered and dark work areas can cause accidents.
- **Do not use your sawmill where there is a risk of causing a fire or an explosion**; e.g. in the presence of flammable liquids, gasses, or dust. Power tools create sparks, which may ignite the dust or fumes.
- **Keep children and bystanders** away while operating a power tool. Distractions can cause you to lose control, so visitors should remain at a safe distance from the work area.
- **Be aware of all power lines, electrical circuits**, water pipes and other mechanical hazards in your work area, particularly those hazards below the work surface hidden from the operator's view that may be unintentionally contacted and may cause personal harm or property damage.
- **Be alert of your surroundings**. Using power tools in confined work areas may put you dangerously close to cutting tools and rotating parts.

## INTERNAL COMBUSTION ENGINE SAFETY



### WARNING!

Internal combustion engines present special hazards during operation and fuelling. Read and follow the warning instructions in the engine Owner's Manual and the safety guidelines below. Failure to follow the warnings and safety standards could result in severe injury or death.

- **DO NOT** run the machine indoors or in an enclosed area such as a deep trench unless adequate ventilation, through such items as exhaust fans or hoses, is provided. Exhaust gas from the engine contains poisonous carbon monoxide gas; exposure to carbon monoxide can cause loss of consciousness and may lead to death.
- **DO NOT** smoke while operating the machine.
- **DO NOT** smoke when refuelling the engine.
- **DO NOT** refuel a hot or running engine.
- **DO NOT** refuel the engine near an open flame.
- **DO NOT** spill fuel when refuelling the engine.
- **DO NOT** run the engine near open flames.
- **ALWAYS** refill the fuel tank in a well-ventilated area.
- **ALWAYS** replace the fuel tank cap after refuelling.
- **ALWAYS** check the fuel lines and the fuel tank for leaks and cracks before starting the engine. Do not run the machine if fuel leaks are present or the fuel lines are loose.
- **ALWAYS** avoid contact with hot fuel, oil, and exhaust fumes.

# PERSONAL SAFETY

- **Stay alert**, watch what you are doing and use common sense when operating a power tool. Do not use a power tool while you are tired or under the influence of drugs, alcohol or medication. A moment of inattention while operating power tools may result in serious personal injury.
- **Dress properly**. Do not wear loose clothing, dangling objects, or jewelry. Keep your hair, clothing and gloves away from moving parts. Loose clothes, jewelry or long hair can be caught in moving parts. Air vents often cover moving parts and should be avoided.
- **Use safety apparel and equipment**. Use safety goggles or safety glasses with side shields which comply with current national standards, or when needed, a face shield. Use a dust mask in dusty work conditions. This applies to all persons in the work area. Also use non-skid safety shoes, hardhat, gloves, dust collection systems, and hearing protection when appropriate.
- **Do not over reach**. Keep proper footing and balance at all times.
- **Remove adjusting keys or wrenches** before connecting to the power supply or turning on the tool. A wrench or key that is left attached to a rotating part of the tool may result in personal injury.
- **Never make blade guide adjustments, remove or install blades or conduct any other maintenance or make any other adjustments when the engine is running**. Always shut the engine off, remove the ignition key, and keep the engine off before carrying out any of the aforementioned procedures. Consult your engine manual for safe shutdown procedures to prevent accident ignition.

# TOOL USE AND CARE

- **Always** be sure operator is familiar with proper safety precautions and operation techniques before using the machine.
- **Never touch** the engine or muffler while the engine is on or immediately after it has been turned off. These areas get hot and may cause burns.
- **Always** close fuel valve on engines when machine is not being operated.
- **Do not force the tool.** Tools do a better and safer job when used in the manner for which they are designed.
- **Never use the sawmill** with a malfunctioning switch or throttle. Any power tool that cannot be controlled with the switch is dangerous and must be repaired before using.
- **Turn off the engine** and place the switch in the locked or off position before servicing, adjusting, installing accessories or attachments, or storing. Such preventive safety measures reduce the risk of starting the power tool accidentally.
- **Secure logs** with the log screw clamping device instead of with your hand or another individual's help. This safety precaution allows for proper tool operation using both hands.
- **Storing sawmill.** When the sawmill is not in use, store it in a dry, secure place or keep well covered and out of the reach of children. Inspect the sawmill for good working condition prior to storage and before re-use.
- **Maintain your sawmill.** It is recommended that the general condition of the sawmill be examined before it is used. Keep your sawmill in good repair by adopting a program of conscientious repair and maintenance in accordance with the recommended procedures found in this manual. If any abnormal vibrations or noise occurs, turn the sawmill off immediately and have the problem corrected before further use.
- **Keep saw blades sharp and clean.** Properly maintained band saw blades are less likely to bind and are easier to control.
- **Cleaning and Lubrication.** Use only mild soap and a damp cloth to clean your sawmill. Many household cleaners are harmful to plastic and rubber components on the sawmill.
- **Use only accessories** that are recommended by the manufacturer for your model. Accessories that may be suitable for another sawmill may create a risk of injury when used on this sawmill.
- **Always operate machine with all safety devices** and guards in place and in working order. DO NOT modify or make changes to safety devices. DO NOT operate machine if any safety devices or guards are missing or inoperative.
- **Never leave the sawmill running unattended.**
- **Coiled blades can spring apart** with considerable force and unpredictably in any direction. Always deal with coiled blades, including those packaged in boxes, with the utmost care.
- **Never use the equipment to cut anything other than lumber** or for any purpose other than cutting lumber as described in this manual.



## EQUIPMENT OPERATION

1. Wear heavy-duty work gloves, ANSI-approved goggles behind a full face shield, steel-toed work boots, and a dust mask.
2. Operate only with assistance.
3. Fill the lubrication tank with clean water and liquid soap.
4. Start and operate the engine according to the provided engine manual.
5. Depress the throttle to bring the blade up to speed.
6. Throttle should be fully depressed when the saw is under load.
7. Cut branches off the lumber to be processed.
8. Place the lumber to be cut on the supports.
9. Move the saw head slowly along the track and against the lumber to make the cut.
10. Trim off the rounded sides of the log.
11. When the log is squared-off, boards or posts can be cut to custom specifications.
12. To prevent accidents, turn off the engine and disconnect its spark plug wire after use. Wait for the engine to cool, clean external parts with a clean cloth, then store the equipment out of children's reach.



### **WARNING!**

To avoid death or serious injury. Do not cut lumber with foreign objects in it such as nails, any metal pieces, etc.



### **WARNING!**

The operator and any assistants must stay clear of the front and back of the blade whenever the engine is on.

## GENERAL MAINTENANCE INFORMATION

Proper and routine maintenance is critical to operator safety, achieving good milling results and to prolonging the life of your investment.

- **Band Wheel Bearings** — Inspect before use to ensure they are not worn. Bearings are sealed and do not need to be greased.
- **Blade Guide Bearings** — Inspect before use for excessive grooves or scoring in the bearing case. Replace if necessary.
- **Blade Tension** — Grease threads of tensioning “T” handle when dry or as required. Use multi-purpose, extreme-pressure grease.
- **Log Screws** — Grease frequently.
- **Belts** — Periodically check the condition and wear of the drive and idler belt. Ensure that the blade does not ride on the band wheels.
- **Drive Belt** — Periodically check the tension of the drive belt.
- **Saw Head Vertical Posts** — Spray posts before use with a silicone spray lubricant such as 3-in-1 or Jig-A-Loo.
- **Band Wheel Guards** — Routinely remove any build-up of sawdust that may collect inside the band wheel guards.
- **Lubrication Tank** — Only fill with a water and dish soap mixture or in winter months, use windshield washer fluid. Do not leave lubricant in tank if temperature falls below 0° C.
- **Blade Lubricant** — Never use diesel fuel or kerosene as blade lubricant. These substances lead to premature wear of your belts and poor sawing performance. For winter operations, replace the water lubricant with windshield washer fluid.
- **Engine** — Check the engine oil level before each use and maintain the engine as per the instructions set out by the engine manufacturer in the engine manual. The engine is equipped with an oil alert system and will not start without adding oil before starting.
- **Saw Head Lifting Cables** — Regularly before, during, and after operations; inspect the cables for any wear or kinks. Ensure that the cables are in perfect condition. Oil coiled part of cable often to prevent premature wear. Replace with new cables as necessary.

# SAWMILL ASSEMBLY

## 1. UNPACKING

Unpack the contents of the crate except for the sawmill head and the two long boxes in the bottom that contain the two sections of track. Unbolt the front of the crate and lay 6" (150mm) high support blocks in front of the crate. Bend the front of the crate down. Carefully lay the sawmill head and the cardboard down onto the 6" (150mm) support blocks. Slide the sawmill head out of the crate as shown below.

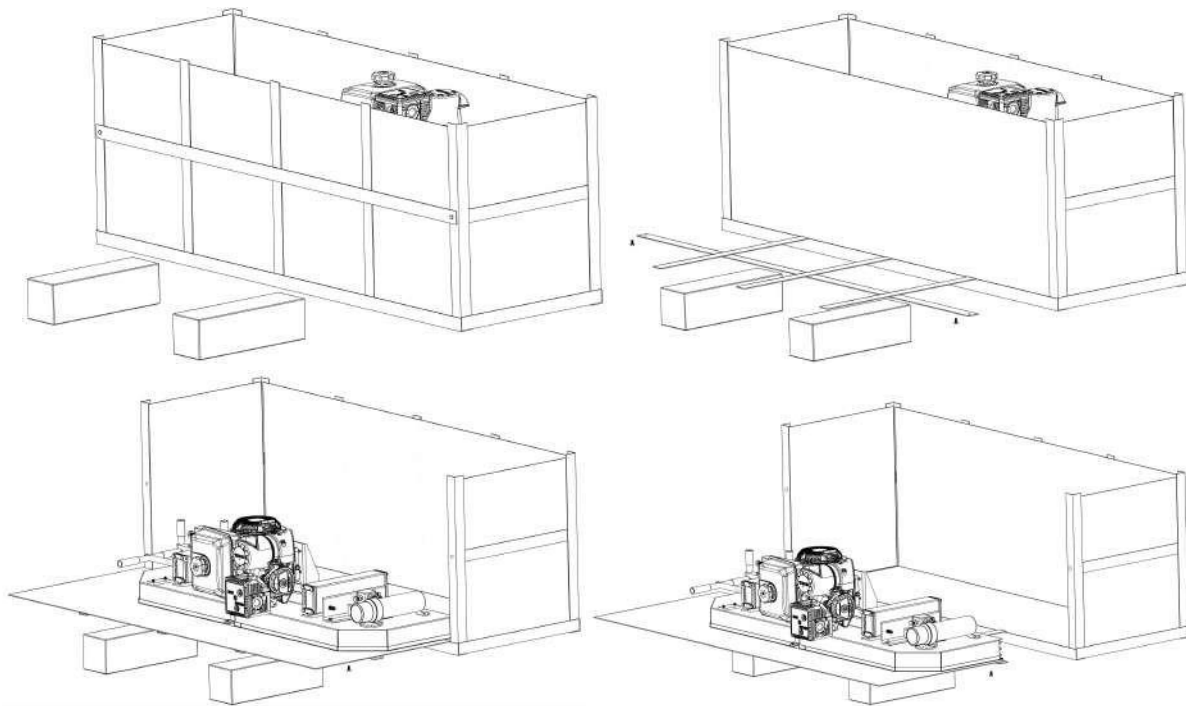

The two long track boxes may now be removed from the crate and the crate be placed out of the way.

## 2 TRACKS

Assemble the track system with the provided nuts & bolts. It is important to assemble and level the track on a firm foundation before tightening all of the nuts and bolts. It is ideal to assemble the tracks on a solid and level footing that is a minimum of 4" (100mm) off of the ground or wood. This will allow for easy cleanup of sawdust from under the tracks.

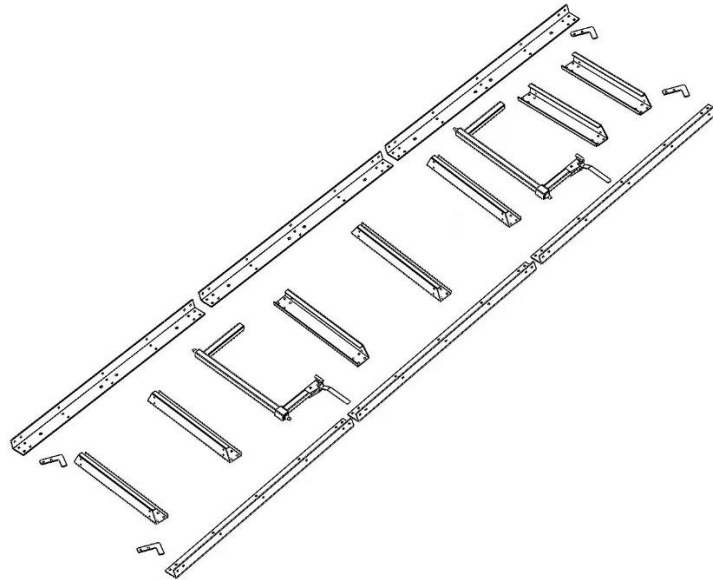

The width of the track should be assembled so that it is 23.8" (605mm) -24" (614mm) wide when measuring the width from the outside to outside of the "L" rails.

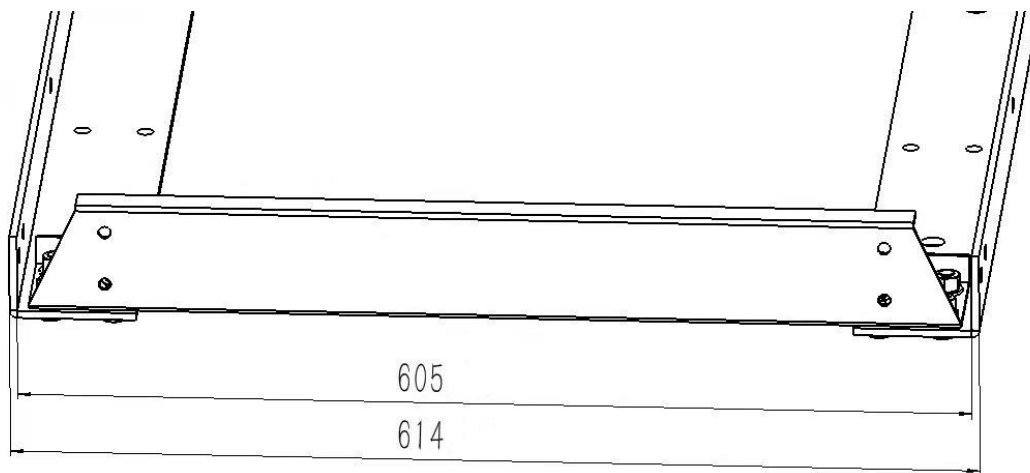

The pictures below show the assembly of the log bunks to the “L” rails. Ensure that the two end bunks are square (90 degrees) to the track ‘L’ rails.

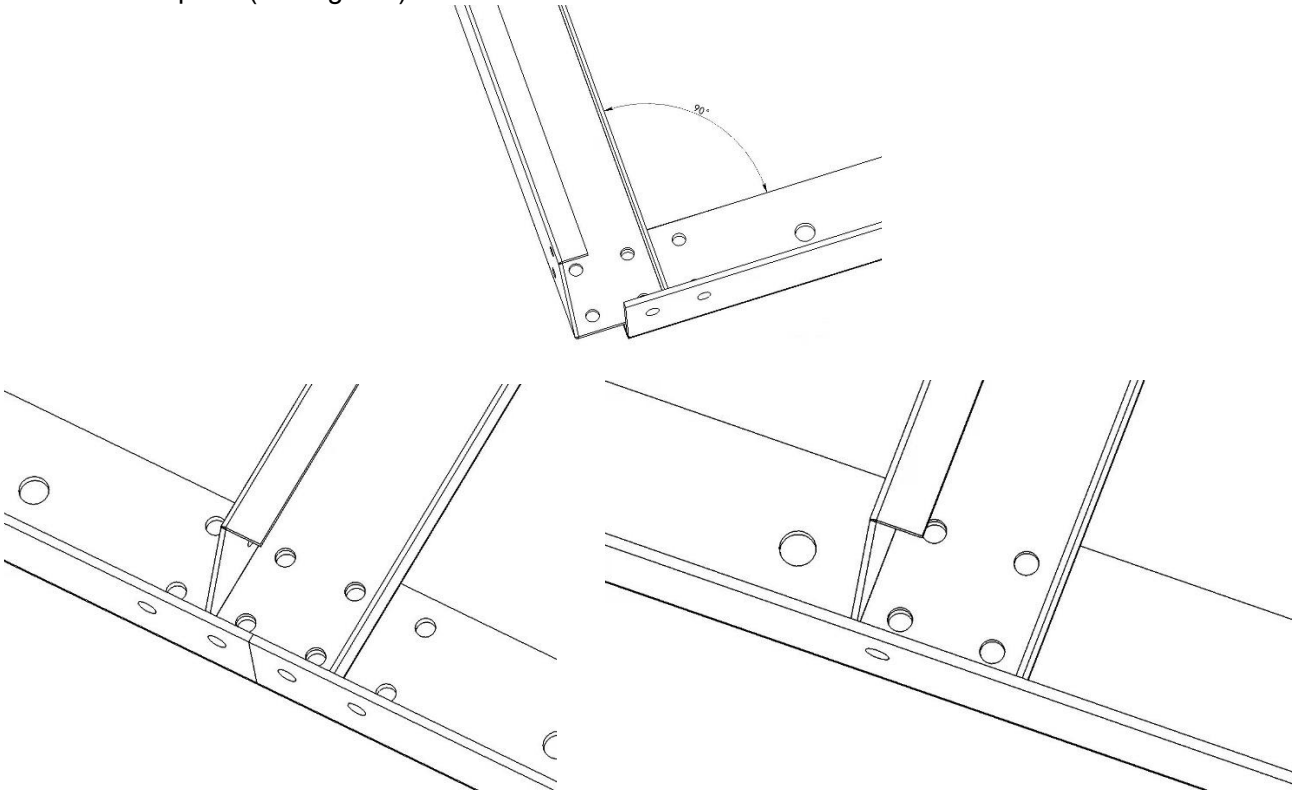

Assemble carriage stops at the ends of the tracks (4 stops total) and tighten bolts as shown below.

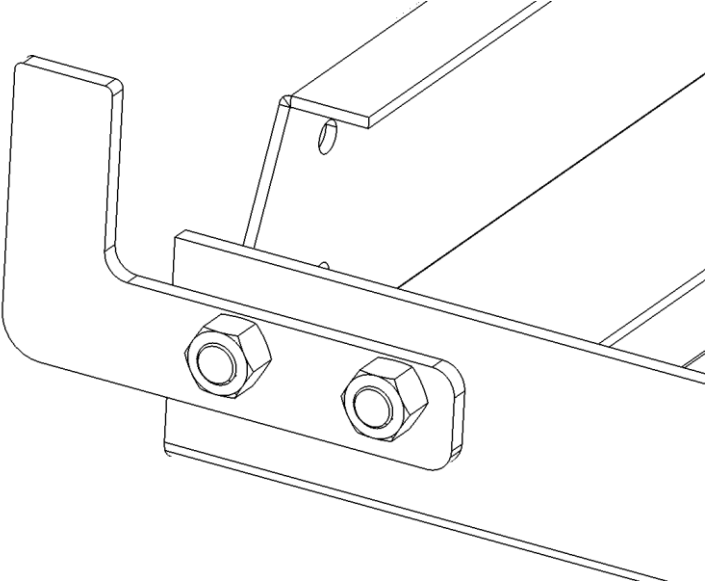

### **3. LOG DOG & SUPPORTS**

Assemble log dog and support pieces using the pieces shown below.

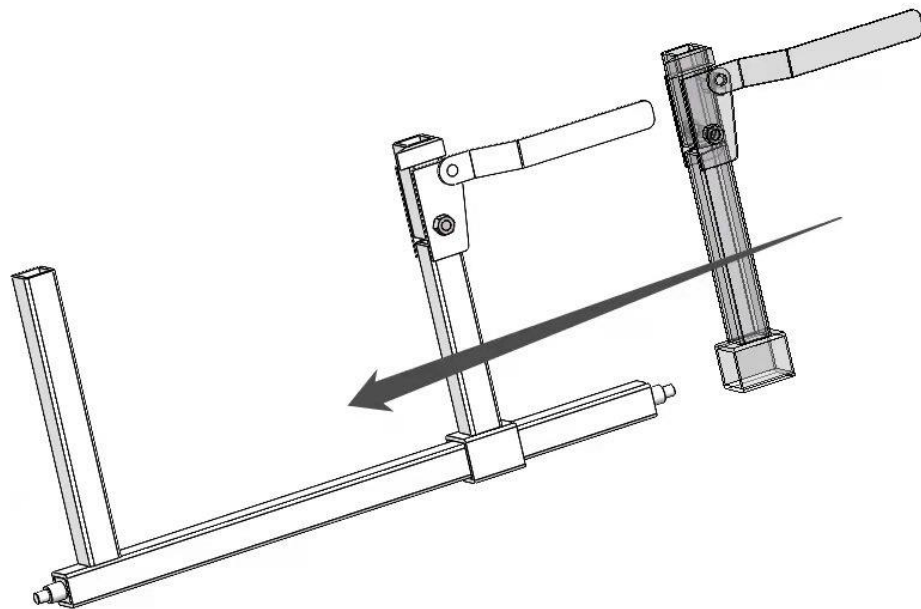
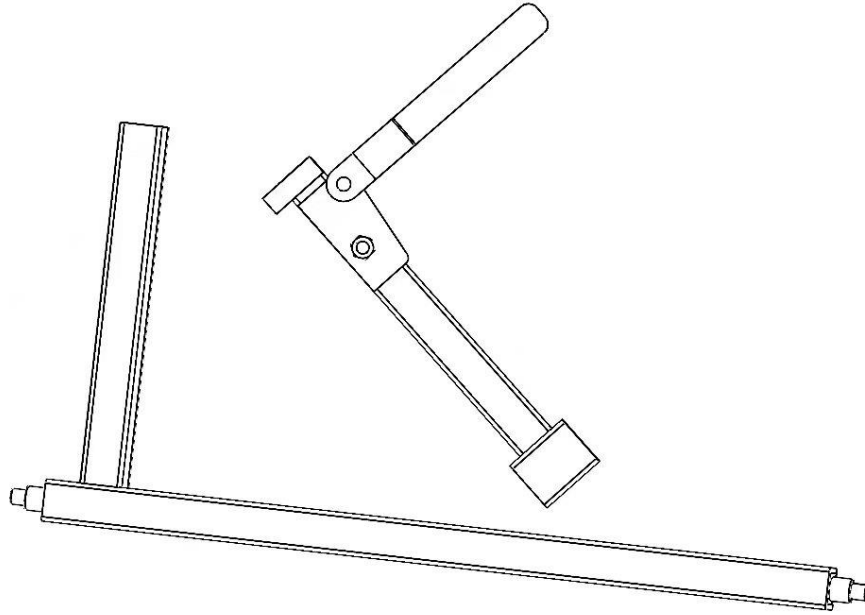

The sawmill includes two sets of log dog and supports. It can adjust the support height by turning log dog right or left.

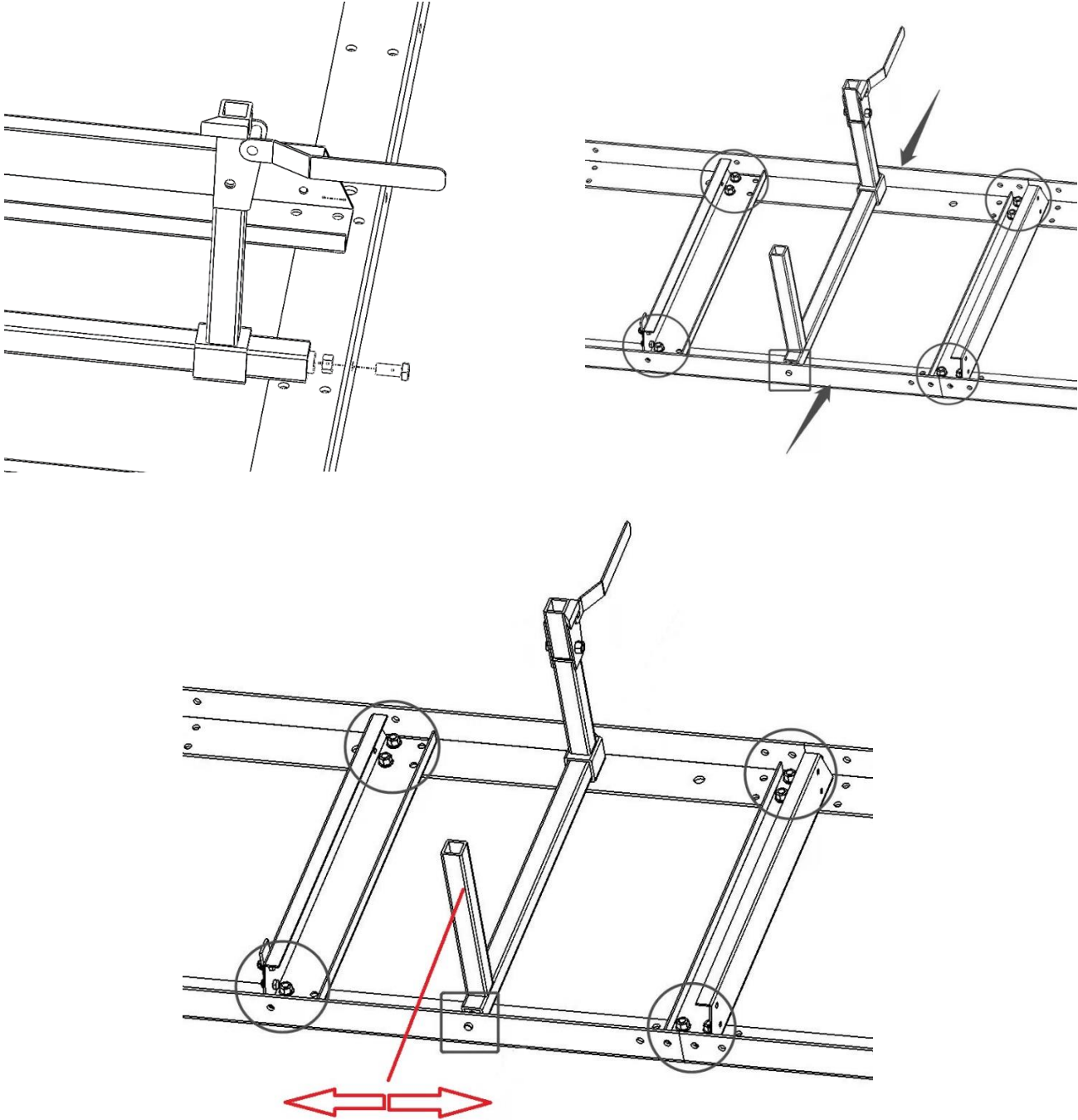

## **4. GROUND TRACK SET UP FOR THE SAWMILL**

### **A. Machine Set-Up (ground track unit) (SEE FIG. A)**

- 1) For best results and easier set-up, the mill location should be level solid ground and free of obstructions.
- 2) A level cement pad is the best option, but square timbers also work well.  
You will need to support the track at each joint and under each cross member of the track.
- 3) You will need to be sure that the mill TRACK is level from front to back and side to side.  
The better the mill track is supported the better the mill will work.
- 4) There should be a 4 ft. clear work area around the entire mill.

### **B. Track Assembly**

- 1) Dogs need to be facing in the same direction, all the movable dogs need to be on the operators side of track.
- 2) There are additional holes in the track so that the dogs can be moved to different positions for cutting shorter or longer logs if needed.
- 3) The tracks are bolted together using the M10x20 bolts and nuts provided.  
The mill track will have 2 bolts/2nuts per section of track. Line up the tracks so that the holes align. Using the provided bolts, put them through the holes and finger tighten the nuts. Adjust the track height so that the 2 pieces of track meet flush and level. Work one side then the other, once level has been achieved, check the track to see if it aligns vertically at the joint. If the track is not aligned correctly use a hammer to tap it into position. Do not tap on the vertical rail. Once this is accomplished tighten the bolts securely.  
NOTE: when the mill head rolls over the track joint it should be smooth. There should be no bump or rise at the track joint. (see fig. B)
- 4) The track comes with four galvanization track stop tabs and the bolts to fasten them to the track. Place the track stops at the four end corners, then bolt on the inside of the track. Place them on the inside corner of the track, secure them into place with the bolt and nut provided. The track stop tabs are placed at an angle over the track to prevent the mill head from rolling off the track at each end . (see fig. C)

Moveable dogs on one side

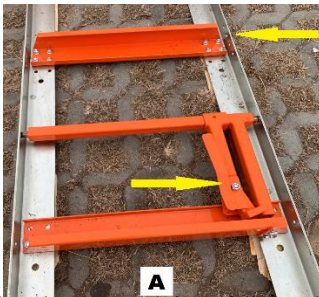

Track on level ground, free of obstructions

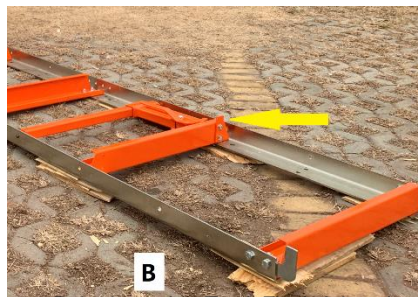

Bolted together Track Flush & Level

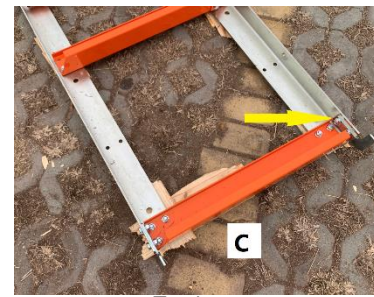

Track stops



- 5) To saw a board accurately, the track needs to be straight and flat. To obtain this, use a string tied tight from end to end or a level. If the track/trailer has a crown or dip, you will not be able to saw a straight board. (see fig.D below.)

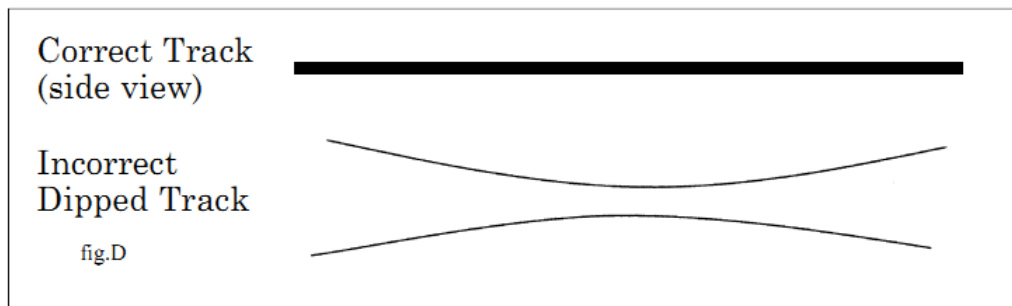

Correct Track Set-Up / Layout

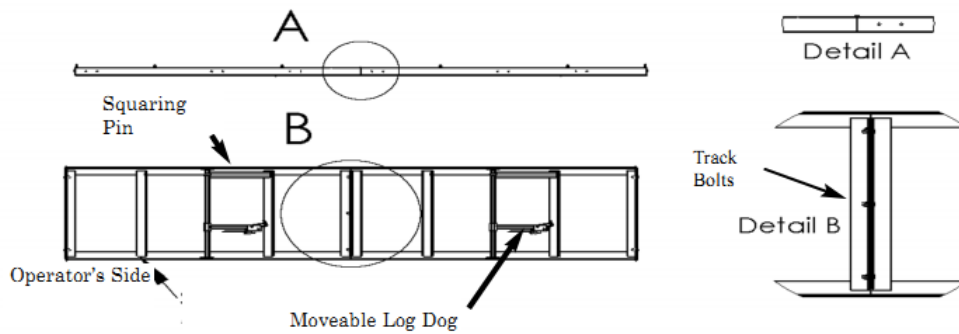

**NOTE : If you set up on soft or frozen ground it's best to check the track daily for levelness due to changing weather and temperature.**

**C. Setting Head on Track, Ground Models**

Once your track is level, you are ready to set the head on the track. Once again, be sure the area is still free and clear of obstructions. You will want the head to roll freely down the track.

- 1) Install the head with operator's side on the same side as the moveable dog. The discharge side is the side with the squaring pins.
- 2) Raise the head 3 inches and roll from one end to the other. The head should roll smoothly along the track. If the head "thumps" when it passes over the track joint, check to make sure the tracks are level. Re-level the track and try rolling the head again. Also be sure to watch the track as you roll the head, if the track moves down or up you will need to use shims to support the track in that area.



Correct head placement; Operators side is on side with the scale stick and hand winch.



Squaring arm on left adjustable dog on right

## 5. SAWMILL HEAD ASSEMBLY

Use 1 and 2 rods connect with the two posts on the left and right and handle as shown below.

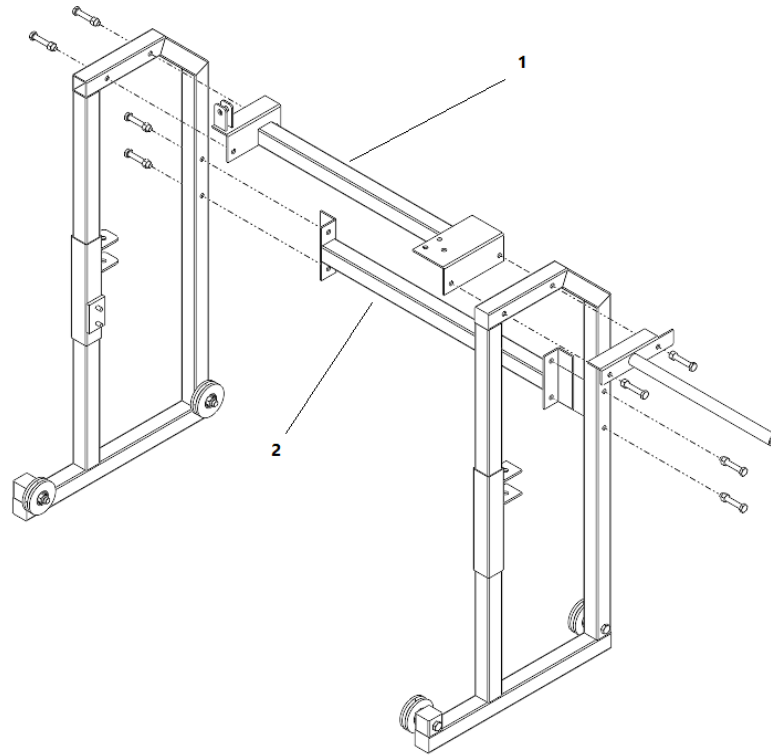

With the help of another person, stand the saw head to its upright position.

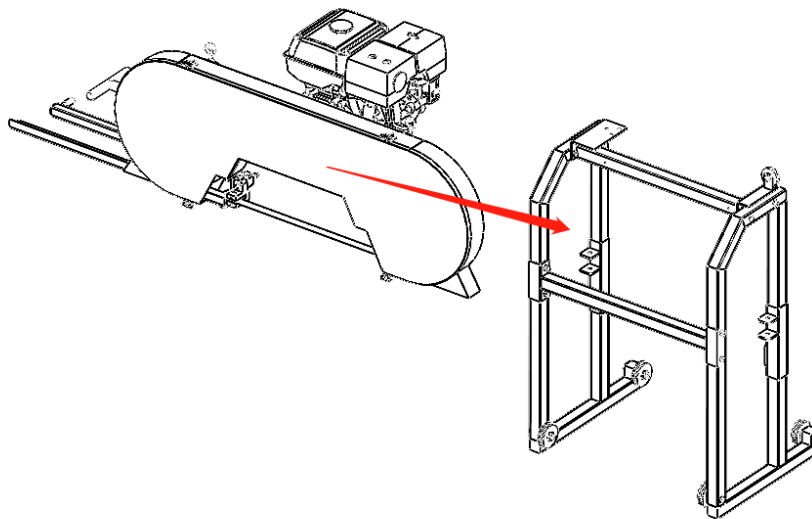

Attach the saw head between the posts using 2 of the M12 x 70mm bolts per side. Do not fully

tighten these bolts at this time.

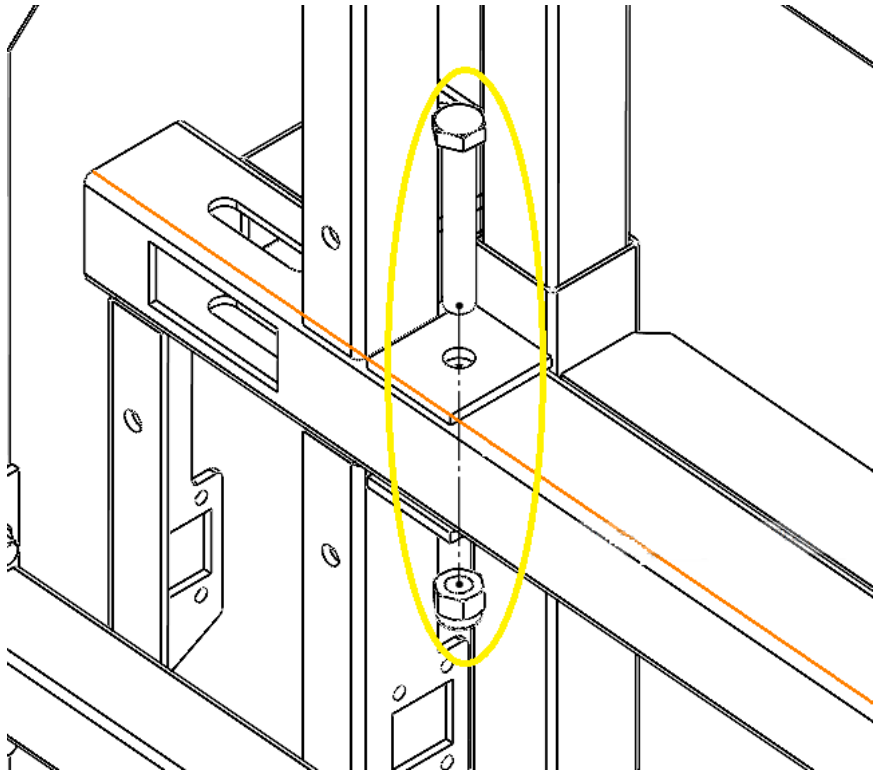
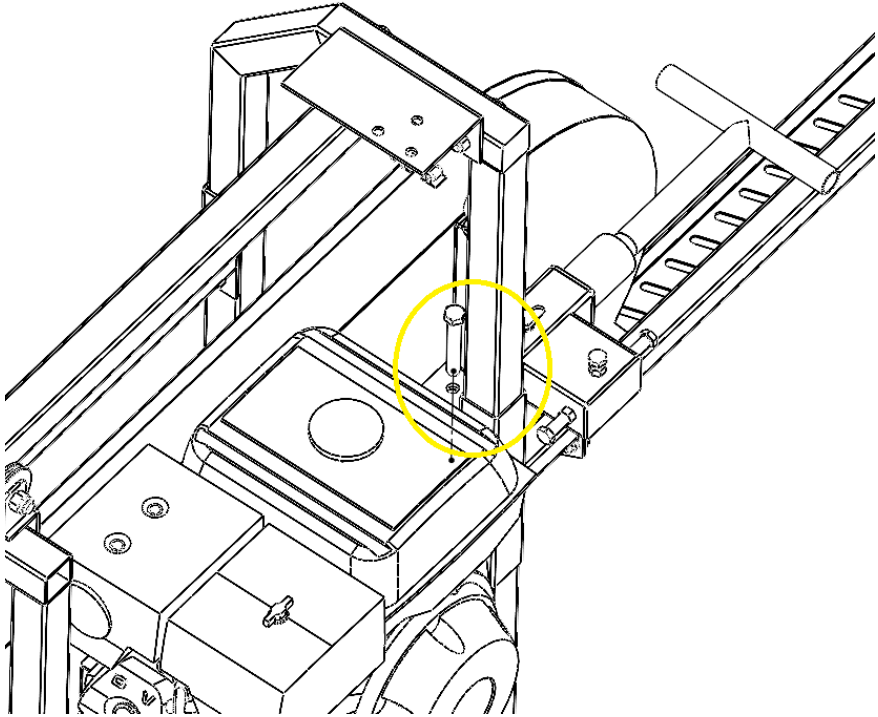

# 1. PLACING THE HEAD ON THE TRACK

Before placing the head on the track, the carriage wheel spacing can be set to ensure they will fit properly on the "L" rails. Check the wheel spacing to ensure that a distance of 24.1" (614mm) is measured from outside to outside of the wheel grooves as shown below.

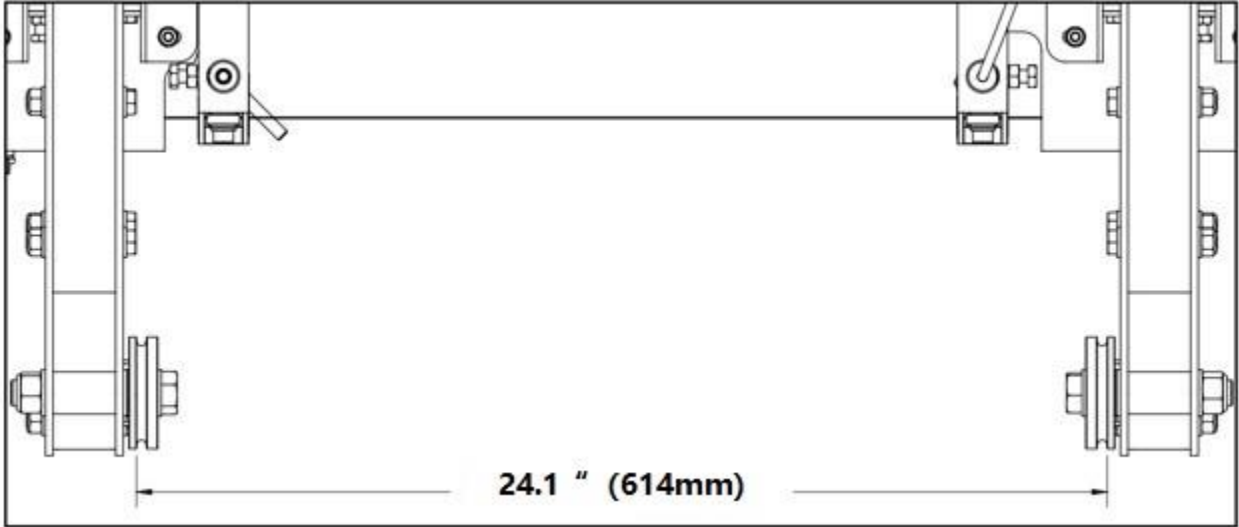

To adjust the width of the wheels, washers may be added or removed from each wheel to ensure a distance of 24.1" (614mm) is achieved.

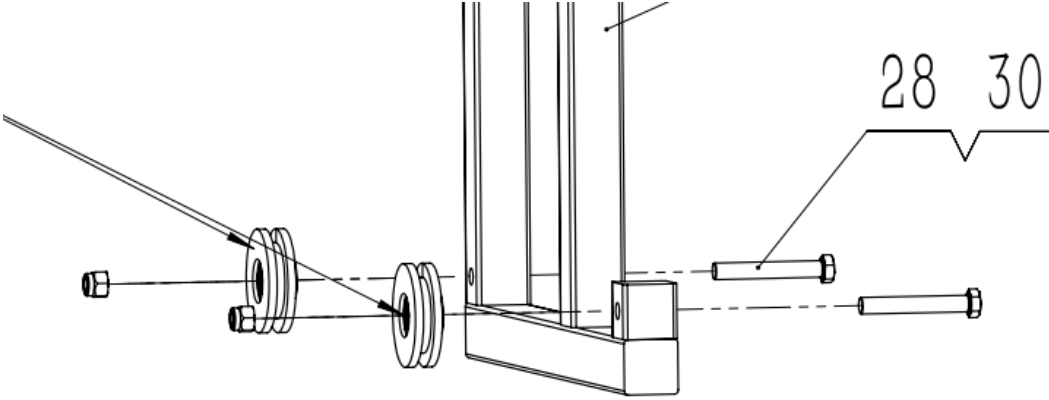

At this point, most of the sawmill head bolts should only be hand tight. They will be fully tightened when the head is on the track and has settled in a true and square state.

Two people are needed for this. Start by removing the "L" shaped brackets on the end of the tracks. The head can be walked over to the track until it is positioned behind the track as shown below. Once in this position, the head can be tilted backwards so that the front two wheels are off the ground. The head can then be walked in place whereas the two front wheels rest it on the track so that the grooves in the carriage wheels fit around the "L" rails. Finally, two people can lift up on the back of the sawmill head and walk it forward so that two back wheels are situated on the track. Finally, the "L" shaped brackets can be re-attached to the track rails.



With the saw head now resting on the track, all of the saw head bolts may be tightened up.

Using a tape measure, take a measurement from the blade to the top of the log bunk on both the left and right side. The distance should be equal on both sides. If it isn't, you will need to adjust the cable ends on the right side to either raise or lower the right side. Refer to the step below for adjustment instructions.

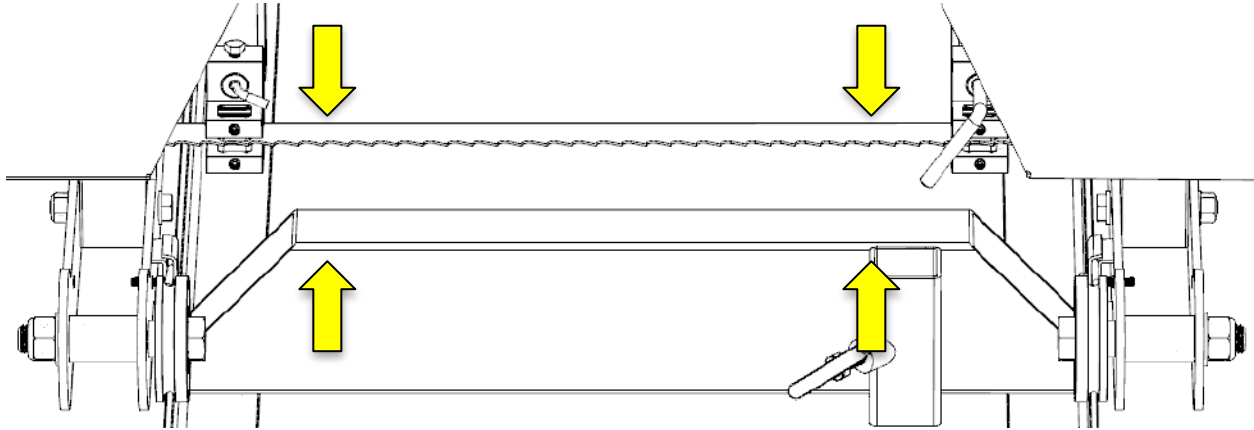

Add waterproof grease to the threads of the blade tension "T" handle and to the washer face that it meets before use. Proper blade tension is achieved when a 24mm socket is used on a torque wrench to tighten the "T" handle to 22 N.M (Max. torque 25N.M) torque. See the images below.

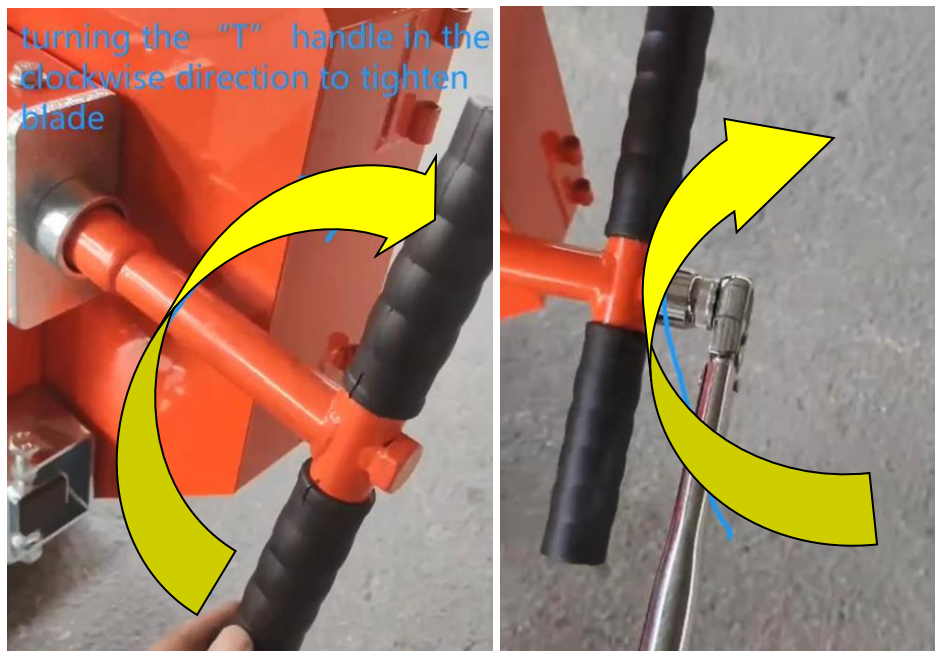

**Note – It is very important to take the tension off of the blade by turning the "T" handle in the counter-clockwise direction when the sawmill is not in use. Failure to do so, will result in flat spots on the rubber belts. These flat spots will cause the mill to vibrate excessively during next use.**

## **2. ENGINE**

Refer to the engine manual before using your sawmill. Please note that the engine does not contain any gasoline or engine oil when it is shipped. Furthermore, the engine is equipped with an oil alert system, meaning that if the crankcase oil level is low or empty, the power is cut to the spark plug and it will not start.

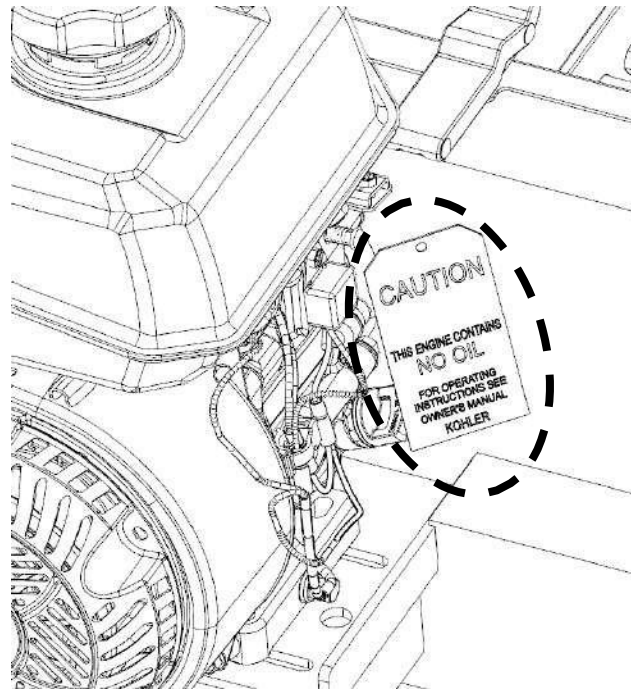

Always cut in the direction shown below. The log clamp should always be on the right side of the log and the log supports should always be on the left. Failure to cut in this direction can cause the log to come loose and possibly even cause damage or injury.

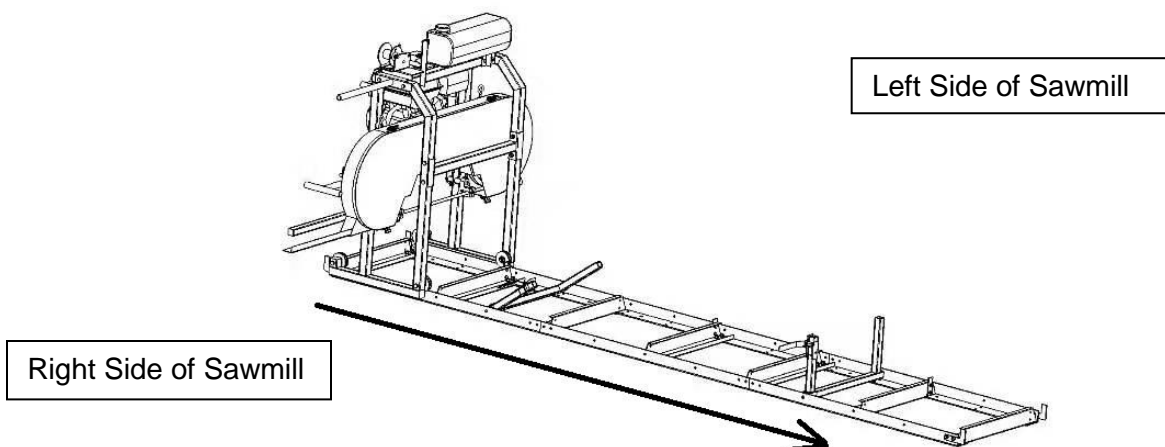

***\*Now that your sawmill is assembled, please run through the "SAWMILL SET-UP PROCEDURES" in the following section. Failure to do so may result in poor sawing performance, damage or injury. See next page.\****

# SAWMILL SET-UP PROCEDURES

## 1. BELT TENSION

**Follower Belt** – This is a polyurethane belt and will be seated tightly in the band wheel vee groove. No adjustment is required for this belt.

**Drive Belt** - To check the belt tension, with your hand, firmly try to deflect the belt up and down. There should be no more than 1/4" (6mm) of deflection. If the belt deflects more than this, it will need to be tightened as described below.

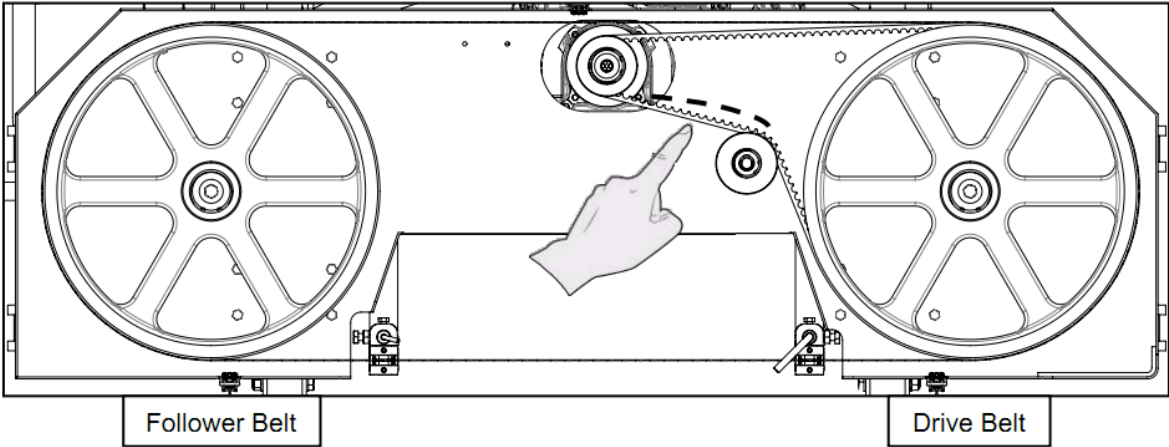

**\*\*Never attempt to adjust the belt tension with the engine running.**

**As a safety precaution, remove the spark plug cap\*\***

To tighten the drive belt, start by loosening the four bolts that secure the engine to the engine mount.

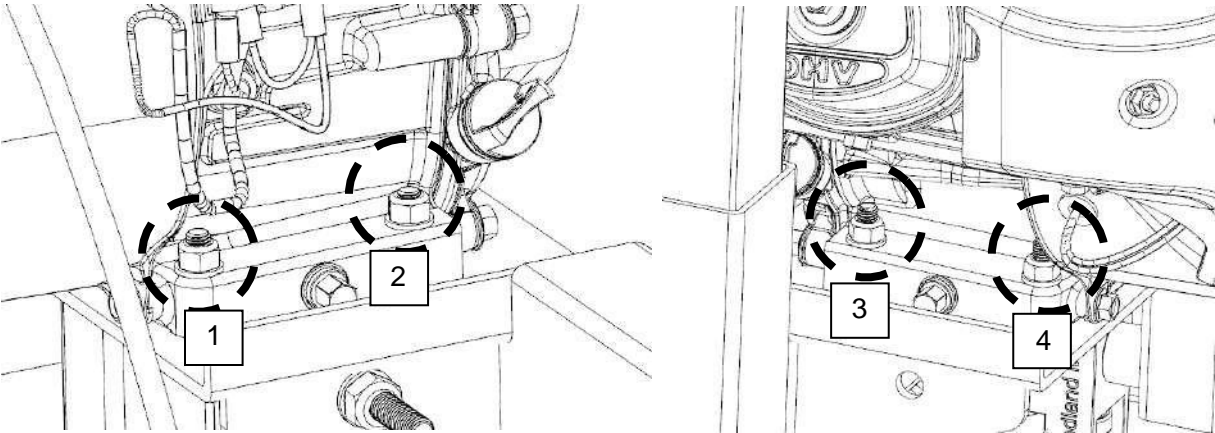



Now that the engine is free to slide on the engine mounting plate, turn the nut on the horizontal stud in the clockwise direction. This will pull the engine towards the stud and apply more tension on the belt. Do this step incrementally while checking the belt for proper deflection. It is also important to ensure that the engine remains perpendicular to the drive belt. Over tightening can cause the engine to twist on the mounting plate, resulting in belt alignment issues and premature wear. Once the desired belt tension is set, tighten the four engine bolts.

Alternatively, if the drive belt is too tight, the nut on the horizontal stud can be turned counter-clockwise.

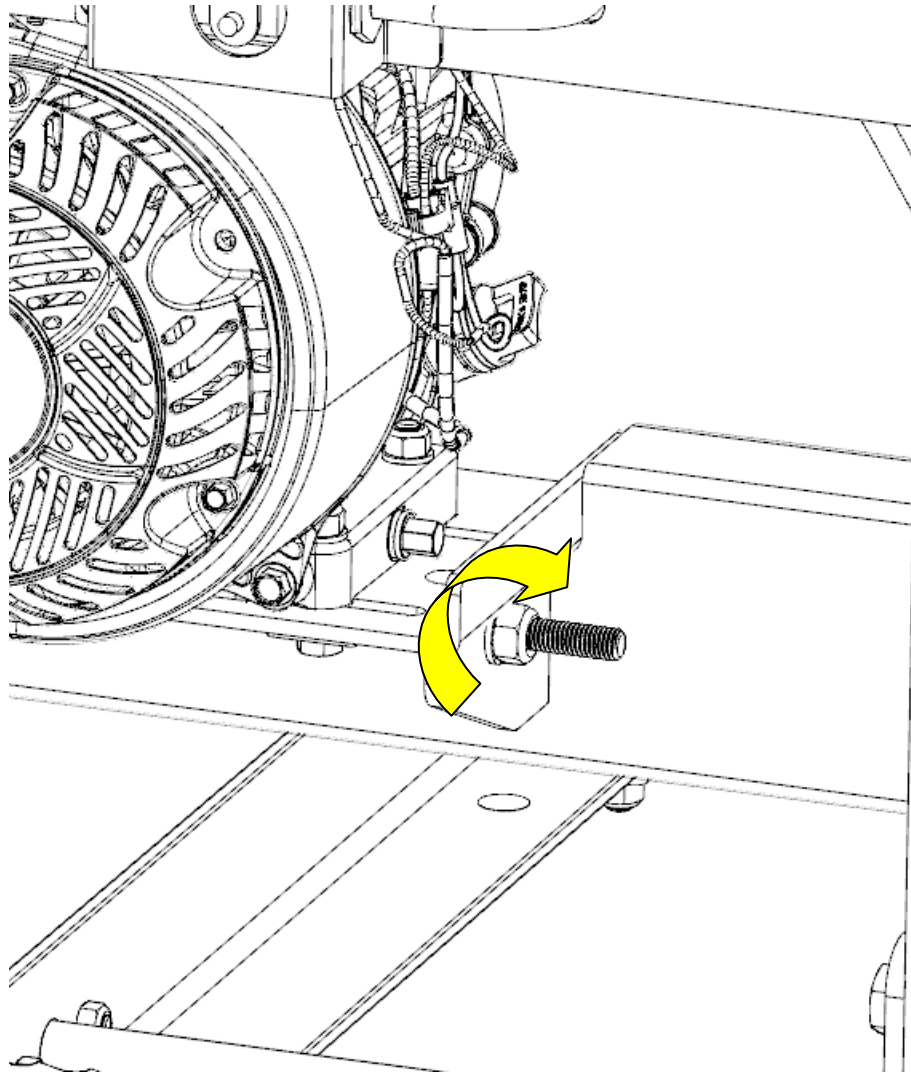

## **2. BLADE TRACKING**

Never attempt to adjust the blade tracking with the engine running. As a safety precaution, remove the spark plug cap. It is also advised to wear gloves and safety glasses when working with the blade as it is extremely sharp.

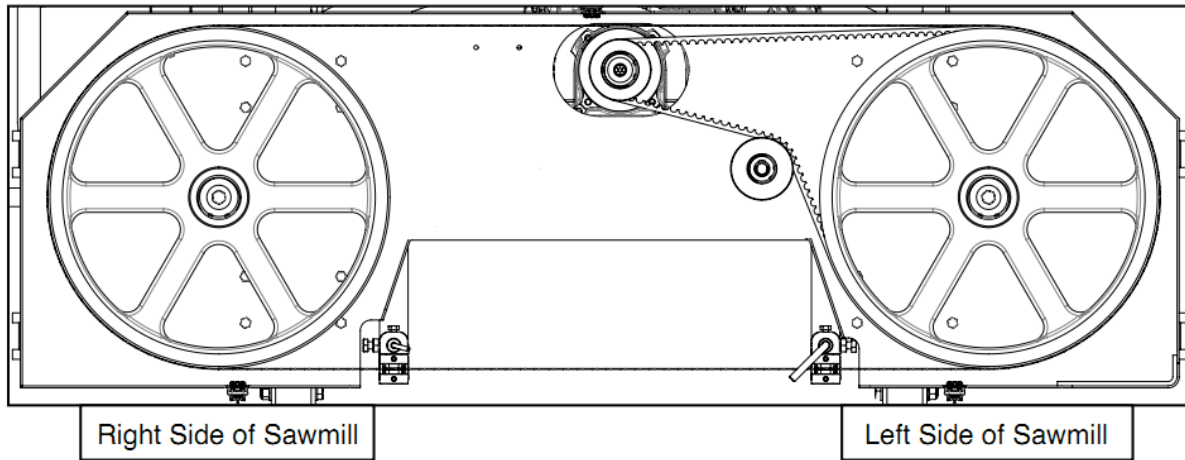

The blade should run with the same tooth to band wheel face distance on both sides. 3/8" (9mm) is ideal. The back of the blade will be flush with the back of the band wheel at this distance and is a quicker check than measuring with a tape measure. If an adjustment on either side is required, the steps below will detail this procedure.

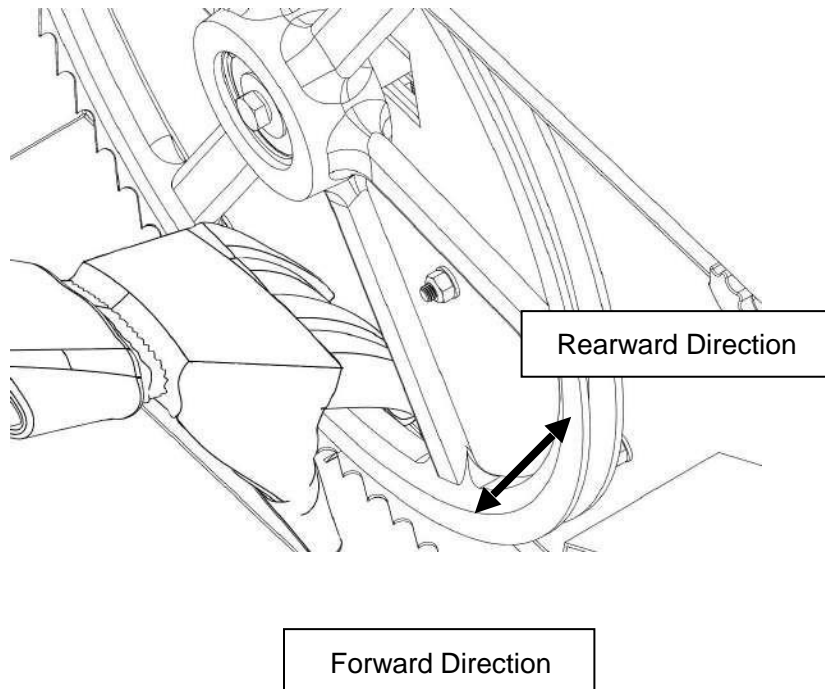

Loosen the blade guide assembly bolt with a 16mm socket. The round shaft should now be free to slide rearward and out of the way. Perform this step on both guide assemblies. This will ensure that the guide bearings do not influence tracking of the blade while adjusting.

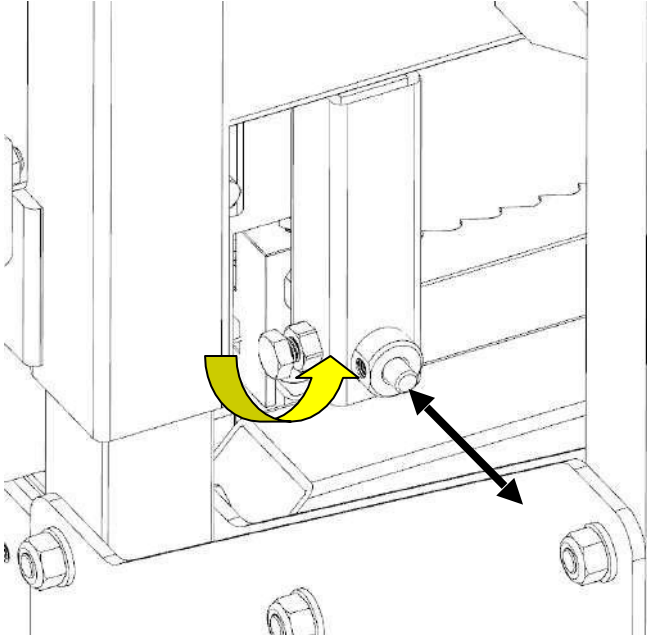

Take some tension off of the blade by turning the "T" handle in the counter-clockwise direction one full turn from full tension position.

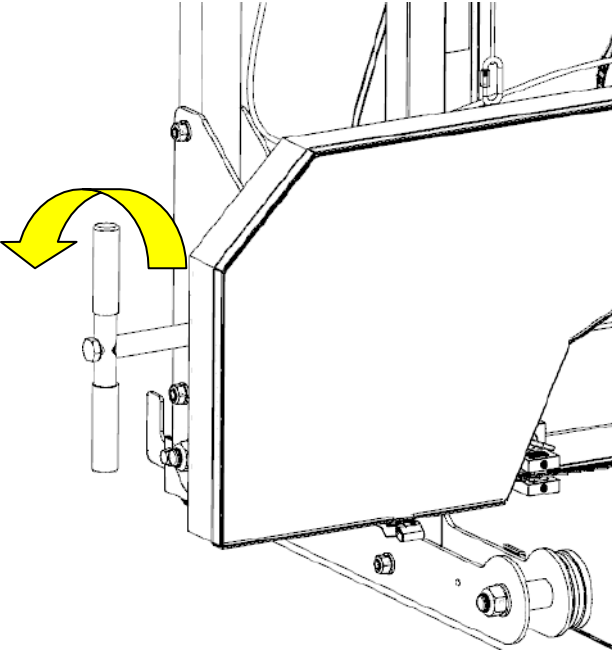

## **Adjusting The Right Hand Side**

Loosen the tracking alignment locking nut with a 16mm wrench or an adjustable wrench.

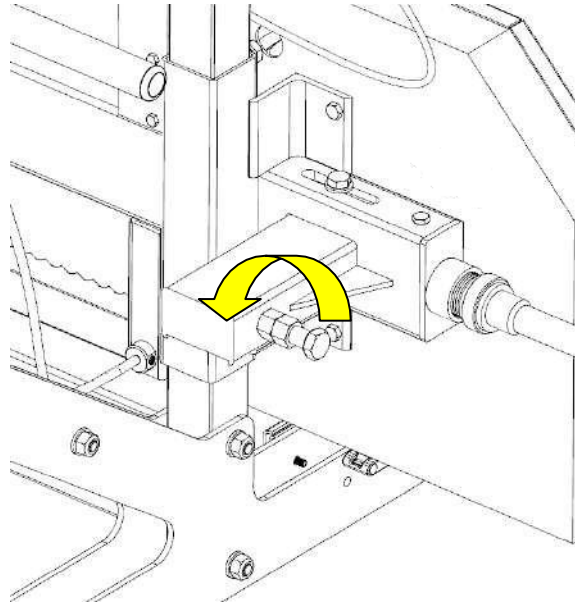

The alignment bolt can now be turned to change the angle of the band wheel and track the blade. To move the blade more rearward on the band wheel, this bolt will need to be turned clockwise. Alternatively, turning the bolt in the counter-clockwise direction would force the blade to run more forward on the band wheel. Turn the bolt a 1/2 turn and re-tension the blade to 22 N.M (Max. torque 25 N.M).

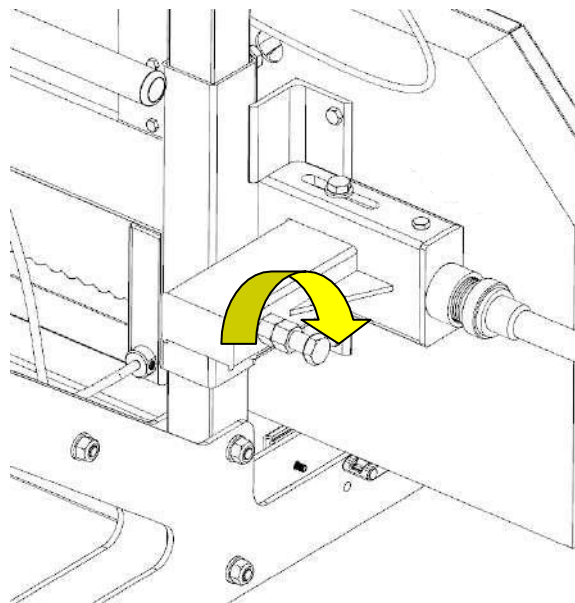

Wearing gloves, spin the band wheel with your hand and observe how the blade has changed tracking. Measure the distance again and repeat the above step to further compensate if required. The ideal measurement is 3/8" (9mm) or check for the back of the blade to be flush with the back of the band wheel.

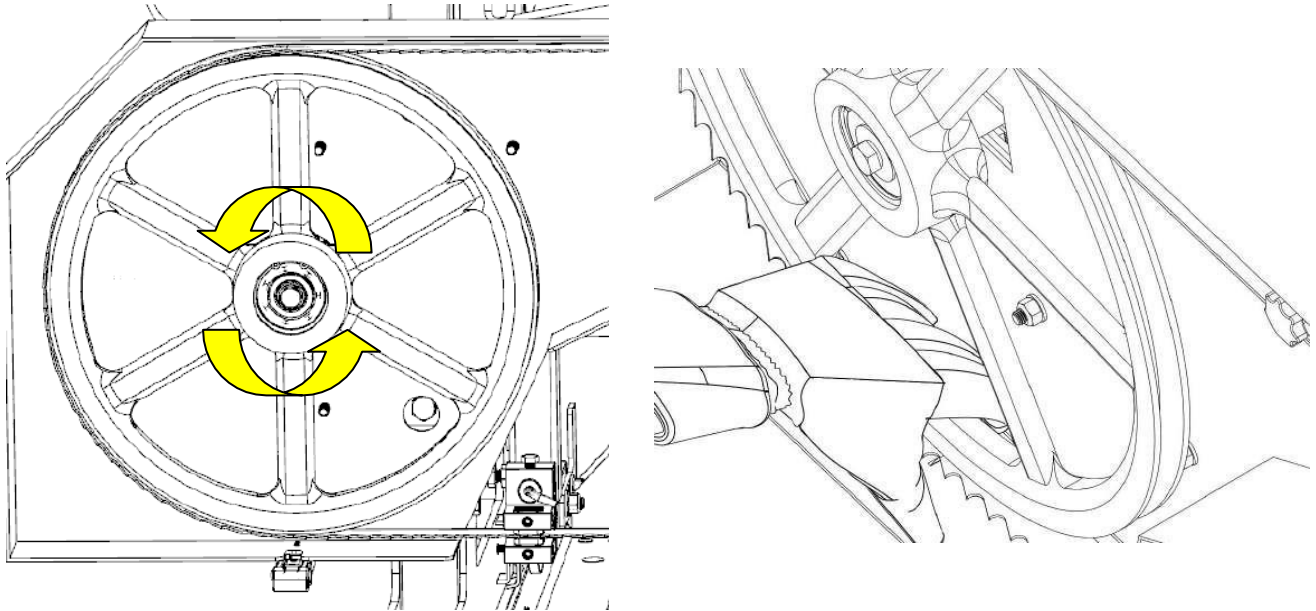

Once satisfied with the measurement, tighten the locking nut clockwise.

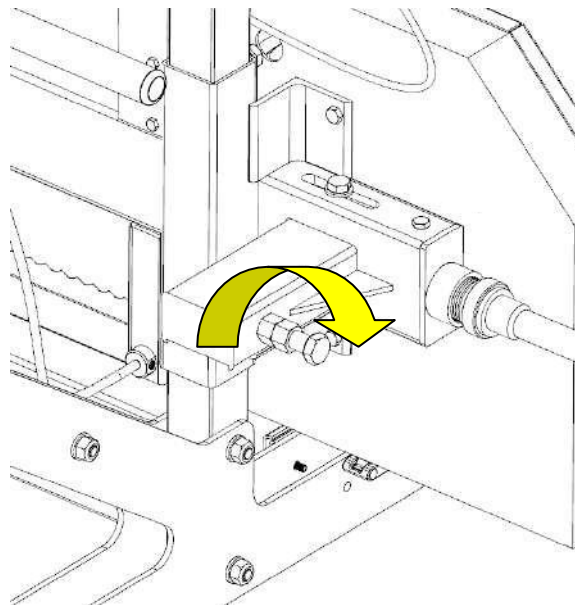

### Adjusting The Left Hand Side

To adjust the left side of the sawmill, again start by taking the tension off of the blade by turning the "T" handle one turn in the counter-clockwise direction. Using an 16mm wrench, loosen the "**vertical nut**" a ½ turn. Next, loosen the "**vertical bolt**" a ½ turn. This will take the clamping force off of the band wheel shaft caused by these two bolts and allow it to move freely in the following steps.

### Moving the Blade Forward

Using a wrench, hold the "**horizontal bolt**" stationary with a wrench and turn the "**horizontal inside nut**" counter-clockwise a ½ turn. Still holding the "**horizontal bolt**" stationary, turn the "**horizontal outside nut**" clockwise a ½ turn. This has now shifted the "**horizontal bolt**" and band wheel shaft, causing the blade to track more forward.

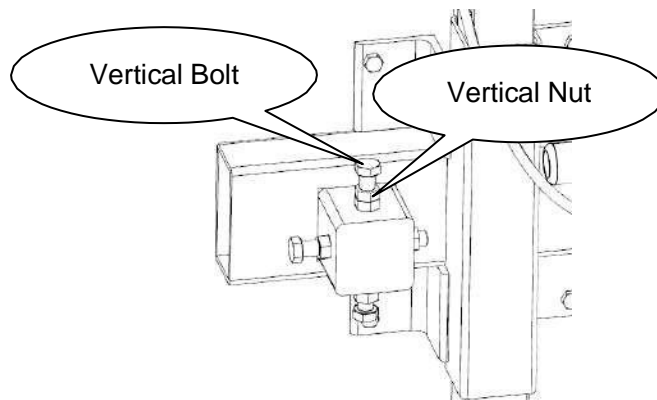

### Moving the Blade Rearward

Using a wrench, hold the "**horizontal bolt**" stationary with a wrench and turn the "**horizontal outside nut**" counter-clockwise a ½ turn. Still holding the "**horizontal bolt**" stationary, turn the "**horizontal inside nut**" clockwise a ½ turn. This step has now shifted the "**horizontal bolt**" and band wheel shaft, causing the blade to track more rearward.

Tighten the vertical bolts, then nuts to clamp the band wheel shaft back into vertical position.

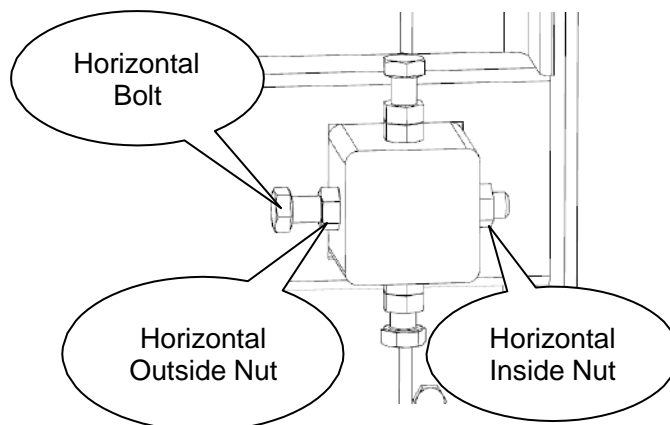

Re-tension the blade by turning the “T” handle a full turn in the clockwise direction (to achieve 22 N.M (Max. torque 25 N.M)). Wearing gloves, spin the band wheel with your hand and observe how the blade has changed tracking. Measure the distance again and repeat the above step to further compensate if required. The ideal measurement is 3/8” (9mm) or check for the back of the blade to be flush with the back of the band wheel. Once the blade is tracking true, bring the blade guide assemblies back up to the blade. Keep a thick paper width (0.040” or 1mm) distance between the blade guide bearing and the back of the blade. More information on this can be found in the next section – **BLADE GUIDE ADJUSTMENT.**

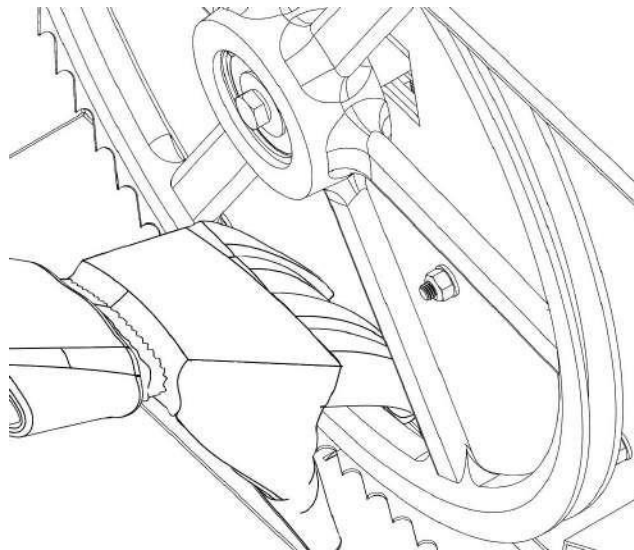
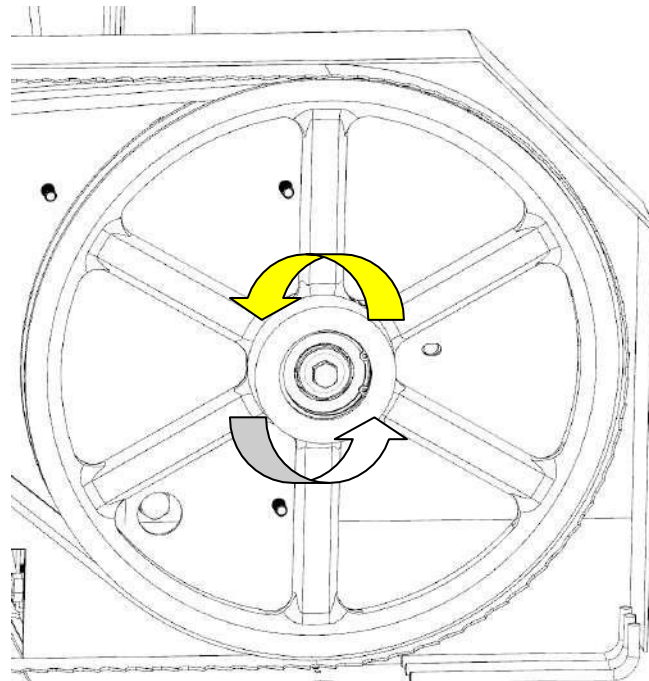

### **3. BLADE GUIDE ADJUSTMENT**

Never attempt to adjust the guide blocks or the guide bearing with the engine running. As a safety precaution, remove the spark plug cap. It is also advised to confirm that the blade is tracking properly before performing the below. Blade tracking is covered in the previous page. Using a 4mm allen key, loosen the blade guide blocks on both the left and right sides. They should be free to slide up and down.

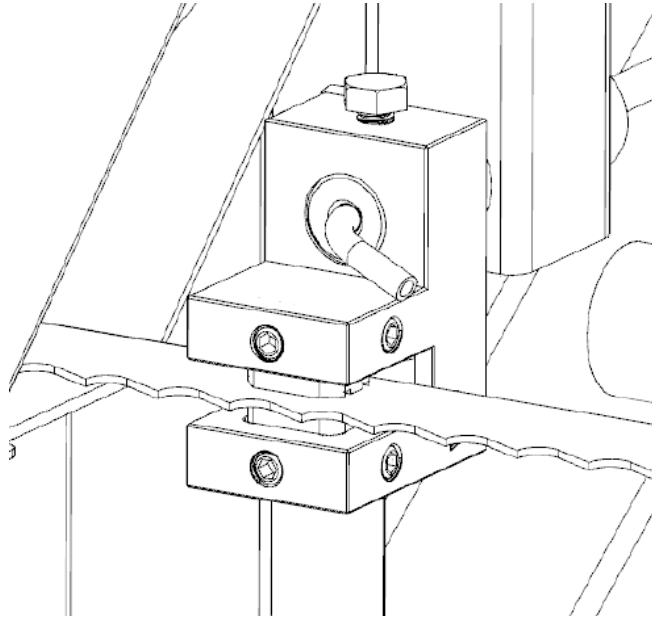

Loosen the blade guide assembly bolt with a 16mm wrench. The round shaft should now be free to slide back and forth. Position it so that there is a thick paper width gap (0.040" or 1mm) between the bearing and the back of blade. Tighten the bolt against the flat on the shaft to secure assembly back in position.

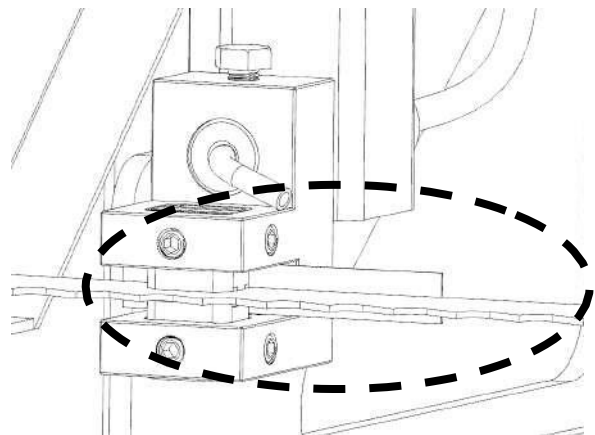
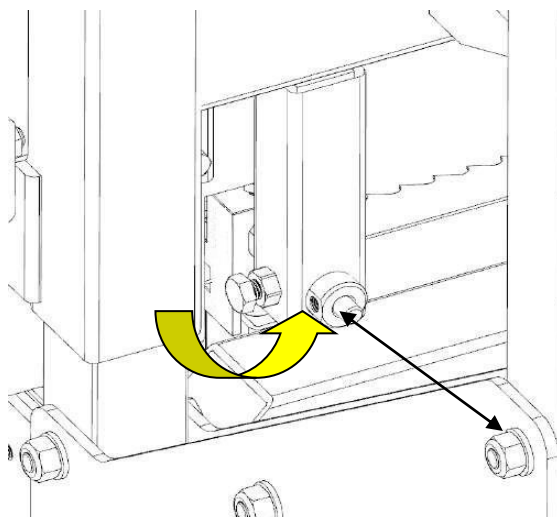



Using a thick piece of paper (0.020" or 0.5mm) in between the blade and both blade guide blocks, tighten the set screws.

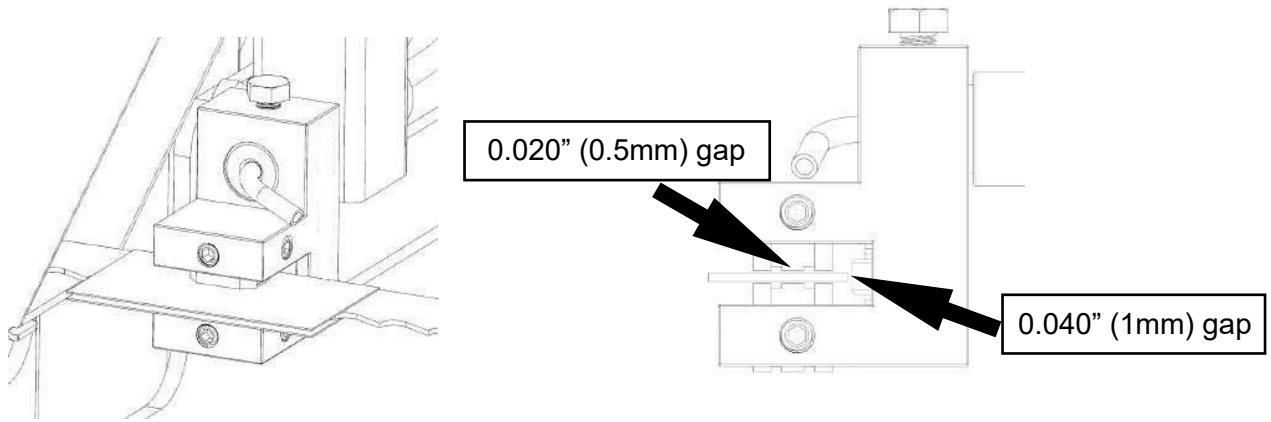

# SAWMILL MAINTENANCE

## 1. BLADE TENSION

Proper blade tension is achieved when a 24mm socket is used on a torque wrench to tighten the “T” handle to 22NM (Max.25 NM) torque. Make sure the spring washers are installed like the picture below.

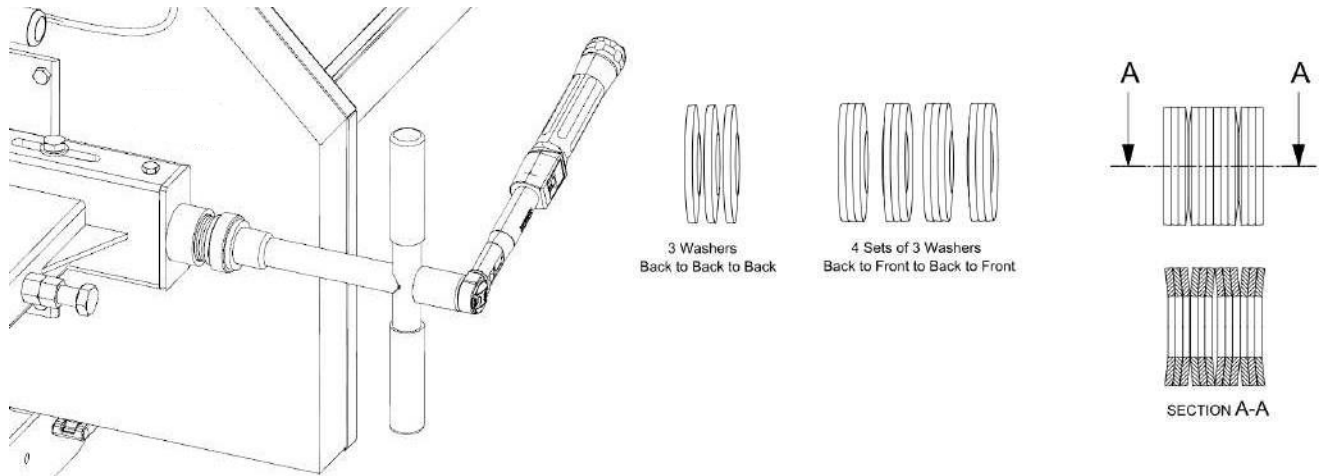

## 2. CHANGING THE BLADE

Never attempt to change the blade with the engine running. As a safety precaution, remove the spark plug cap. Gloves and safety glasses must be worn when changing the blade.

Remove the tension in the blade by turning the “T” handle in the counter-clockwise direction and then open the blade guard cover. The blade should now be loose and free to pull straight out the front. The new blade can now be installed, guards closed and proper blade tension set.

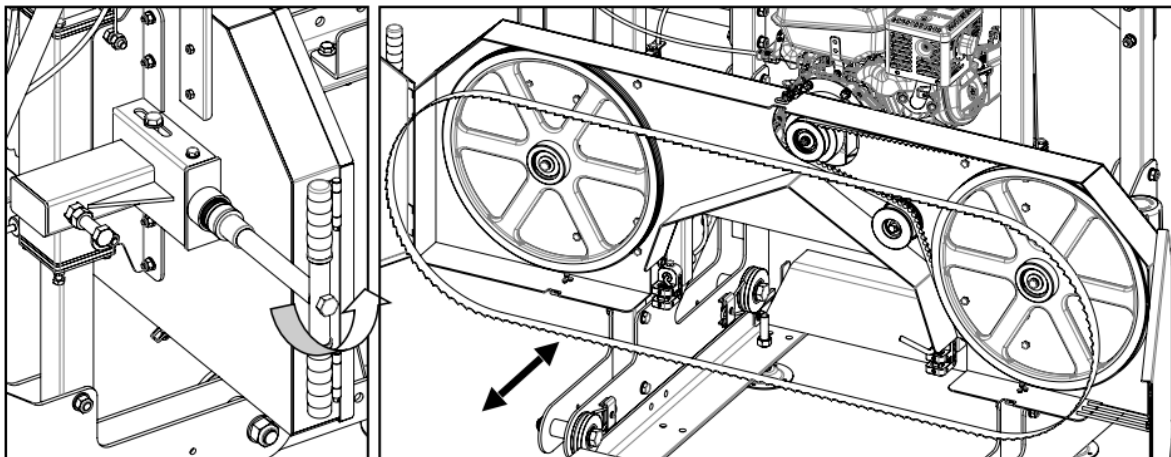

### **3. REPLACING BELTS**

Never attempt to replace the belts with the engine running. As a safety precaution, remove the spark plug cap. Gloves and safety glasses must be worn when replacing the belts. There are two v belts on the sawmill. It is recommended to use a B1727 cogged belt for the drive side and a Woodland Mills polyurethane follower belt.

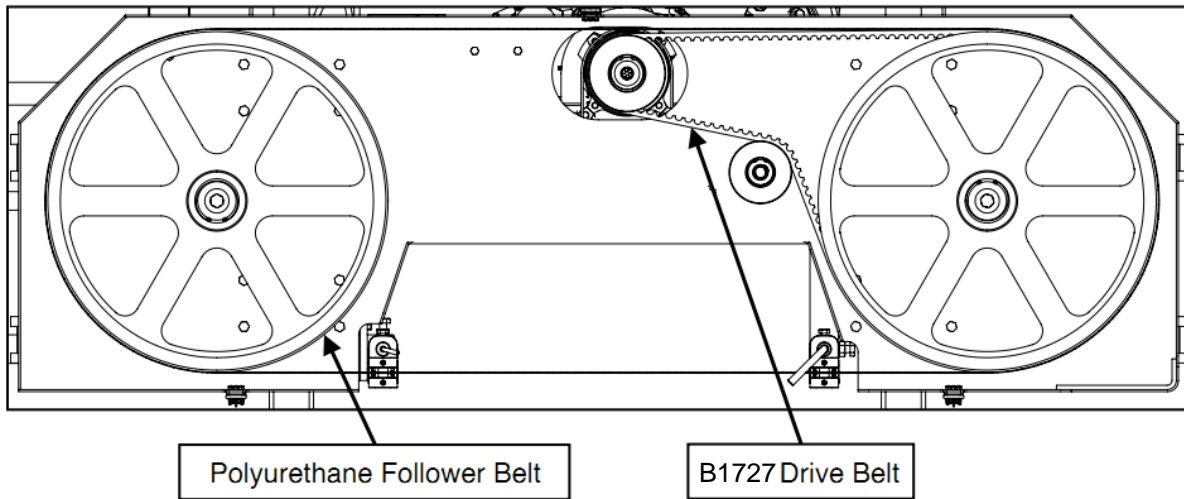

Release the tension in the blade by turning the "T" handle in the counter-clockwise direction and then open the blade guard cover. The blade should now be loose and free to pull straight out the front.

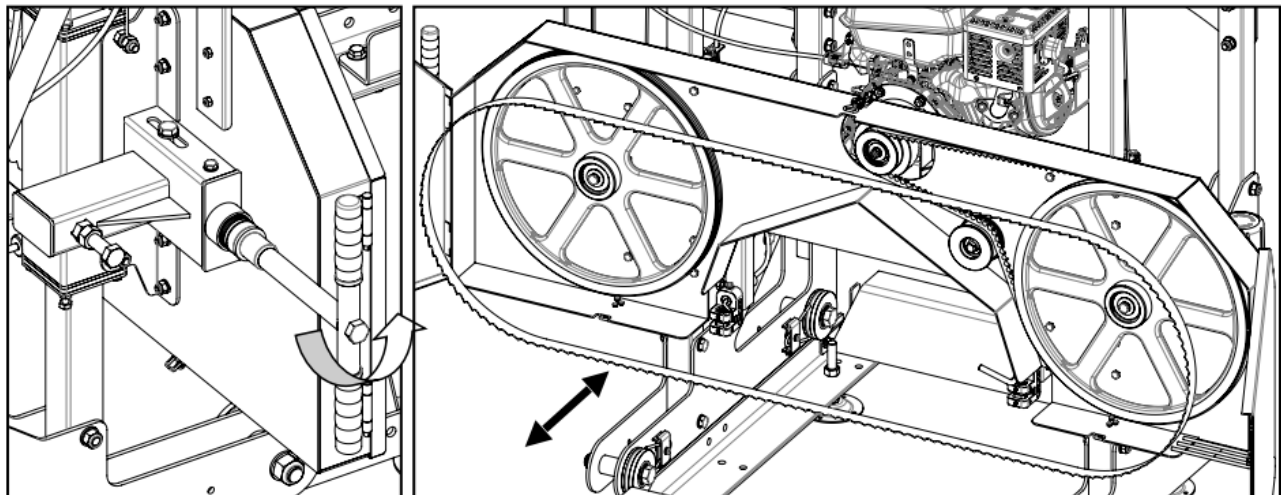

To change the drive side belt, loosen the four bolts that secure the engine to the engine mount using wrenches.

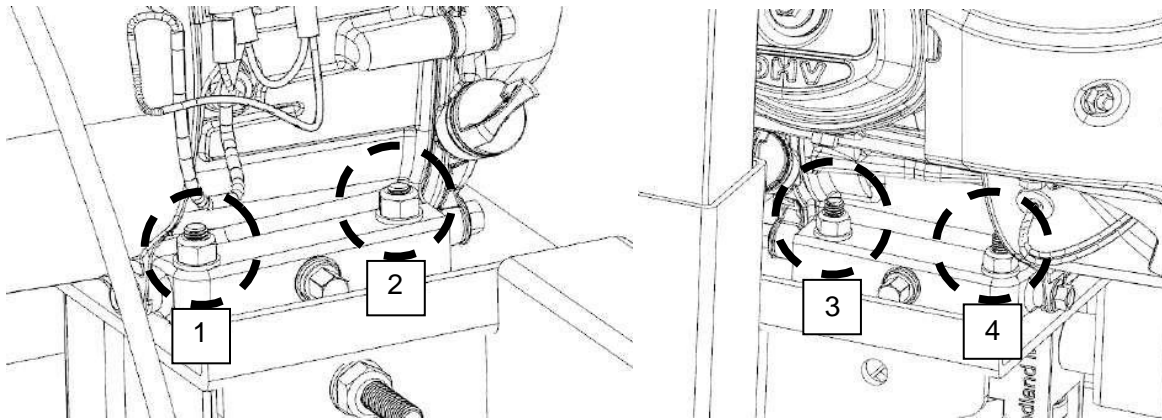

Now that the engine is free to slide on the engine mounting plate, turn the 17mm nut on the horizontal stud in the counter-clockwise direction. This will allow the engine to move and will also take the tension off of the belt. The old belt can be removed and the new belt can be installed. Tension the new belt and refer to the **BELT TENSION** instructions described in the sawmill set up section of the manual.

The follower belt can now be changed by prying it off and installing the new one with the aid of slotted screw drivers. The blade can now be re-installed, guards closed and proper blade tension set.

***Note that blade tracking is likely to change and need adjusting when new belts are installed. Refer to "BLADE TRACKING" for more information.***

# TROUBLE SHOOTING

Problem	Cause	Solution
<b>Blade is Diving/ Rising</b>	<ul style="list-style-type: none"> <li>• Dull Blade • RPM's Not High Enough</li> <li>• Blade Not Tensioned Properly</li> <li>• Sawing Soft Pitch Wood</li> <li>• (Pitch Build-Up in Blade Gullets)</li> </ul>	<ul style="list-style-type: none"> <li>✓ Sharpen or Replace Blade</li> <li>✓ Saw at Full Throttle</li> <li>✓ Check Torque on Tensioning Bolt (Perform "Flutter" Test)</li> <li>✓ Use Lubricant on Blade</li> <li>✓ <b>PETROLEUM PRODUCTS, MINERAL OIL OR VEGETABLE OIL SHOULD NOT BE USED ON OUR MILLS</b> - Saw Tree from the Top to the Bottom (small end to wide end) Slow Down</li> <li>✓ Reset Teeth to Proper Set</li> </ul>
<b>Mill Sawing Hard</b>	<ul style="list-style-type: none"> <li>• RPM's Not High Enough on Engine</li> <li>• Belt is Slipping • Sawing Hardwood Dull Blade • Bark or Sawdust Build-up on Wheels or Track</li> </ul>	<ul style="list-style-type: none"> <li>✓ Always Saw at Full Throttle</li> <li>✓ Adjust Belt Tension Slow Down your Sawing Speed</li> <li>✓ Sharpen or Replace Blade</li> <li>✓ Clean Wheels and Track</li> </ul>
<b>Clutch Slipping</b>	<ul style="list-style-type: none"> <li>• Dull Blades</li> <li>• Debris and/or Oil can cause slippage</li> <li>• Pushing the saw too fast through log</li> </ul>	<ul style="list-style-type: none"> <li>✓ Sharpen or Replace</li> <li>✓ Clean out clutch bell Inspect/repair springs and shoes</li> <li>✓ Slow down</li> </ul>
<b>Engine Powers Down Losing RPM's</b>	<ul style="list-style-type: none"> <li>• Pushing the Mill too Fast</li> <li>• Dirty Air Filter Dull Blade</li> </ul>	<ul style="list-style-type: none"> <li>✓ Slow Down your Sawing Speed</li> <li>✓ Clean/Change Sharpen/Replace Blade</li> </ul>
<b>Mill not Sawing Square</b>	<ul style="list-style-type: none"> <li>• Over Dogged</li> <li>• Track Not Level &amp; Square</li> <li>• Cables are Out of Line</li> <li>• Guides are Out of Adjustment</li> <li>• Not Putting Flat side of Cant Flush with Squaring Post on the First Turn</li> <li>• Bad Trolley Bearing</li> </ul>	<ul style="list-style-type: none"> <li>✓ Loosen Dog Pressure</li> <li>✓ Level Track</li> <li>✓ Re-adjust Cables</li> <li>✓ Re-Adjust Blade Guides Put Cant on Flat side, Flush with Squaring Post</li> <li>✓ Replace Trolley Wheel</li> </ul>
<b>Log Moves When Dogged</b>	<ul style="list-style-type: none"> <li>• Over Dogged, too Much Pressure on Dogs</li> </ul>	<ul style="list-style-type: none"> <li>✓ Loosen Dog Pressure</li> </ul>
<b>New Blade Will Not Cut</b>	<ul style="list-style-type: none"> <li>• Blade Could Be Turned Inside Out</li> </ul>	<ul style="list-style-type: none"> <li>✓ Turn the Blade So That the Teeth are Pointing to the Discharge Direction</li> </ul>
<b>Boards have Fine or Large Lines in them Every Several Inches in a Repeating Pattern</b>	<ul style="list-style-type: none"> <li>• A Tooth in the Blade is Out of Set</li> </ul>	<ul style="list-style-type: none"> <li>✓ Reset Tooth in Blade</li> </ul>
<b>New Blade Will Only cut a short distance in Log</b>	<ul style="list-style-type: none"> <li>• Dull Blade</li> <li>• Debris and/or Rocks or Dirt imbedded in the bark</li> <li>• Pushing the saw too fast through log. Nails or Hardware in the log not seen under the bark.</li> </ul>	<ul style="list-style-type: none"> <li>✓ You will need to Debark your logs if they are dirty or muddy, even clean looking logs have dirt in the bark, Get a Debarking Tool or clean the log with an AX or pressure wash with water. Hardware look for Nails, staples, fencing, insulators, etc, protruding from the log, cut out or cut off log. Slow Down your Sawing Speed and watch for rocks and dirt in the bark and remove it.</li> <li>✓ Clean/Change Sharpen/Replace Blade</li> </ul>

## PARTS LIST

No.	Description	Qty.
1	Track	6
2	Wood base	7
3	Wood clamp	2
4	Track limit	4
5	Track limit bolts M8*20	8
6	Track limit nuts M8	8
7	Wood base limit	3
7.1	Wood base limit bolts M8*16	14
8	Track connect bolts M10*20	44
9	Track connect nuts M10	44
10	Lifting frame(Left)	1
10.1	Lifting frame(Right)	1
11	Winch frame	1
12	Water tank frame	1
13	Water tank	1
14	Track wheel	4
14.1	Track wheel bushing	4
15	Saw blade guide frame(Left)	1
16	Handel	1
17	Posts center support beam	1
18	Pulley	1
19	Ruler frame	1
20	Winch	1
21	Short winch cable	1
22	Long winch cable	1
23	Winch cable clip	1
24	Ruler guide	1
25	Ruler base bolts M6x30	2
25.1	Ruler base nuts M6	2
26	Nuts M10	10
27	Water tank bolts M12*45	1
28	Track wheel bolts M12*80	4
29	Posts connect frame M10*55	4
30	Track wheel flange nuts M12	4
31	Winch bolts M10*20	2
32	Sawmill front cover	1
33	Blade	1
34	Flywheel bolts M10*16	2
35	Flywheel flat pad Ø10*Ø35*3	2
36	Circlip 52	2
37	Flywheel bearing 6205	4
38	Clutch	1

39	B1727 belt	1
40	Following flywheel	1
40.1	Drive flywheel	1
41	Sawmill back cover	1
42	Sawmill back cover locknut M8	8
43	Brush	2
44	Brush adjust position handle	2
45	Sawmill cover fastener	4
46	Flywheel shaft(Left)	1
46.1	Flywheel shaft(Right)	1
47	Tension pulley bolt M8*16	1
48	Tighten pulley flat pad	1
49	Tighten wheel bearing 6203	1
50	Tighten pulley	1
51	Tighten pulley shaft	1
52	locknut M12	1
53	Saw blade guide frame(Right)	1
54	Flywheel adjust bolts M10*55	2
55	Flywheel lock bolts M10*35	6
56	Engine	1
57	Saw blade guide bolts M10*16	1
58	Saw blade guard frame	1
59	Saw blade cover	1
60	Saw blade cover connect plate	1
61	Nylon bushing	2
62	Nylon bushing plate	1
63	"T" following flywheel shaft adjust handle	1
64	Following flywheel shaft adjust fasten case	1
65	"T" lead screw unit	1
66	Engine fix bolts M8*40	4
67	Nylon bushing plate locknuts M6	8
68	Nylon bushing bolts M6*30	4
69	Nylon bushing bolts M6*16	4
70	Flywheel location bolt M10x80	1
71	Spring Ø2*Ø25*52	2
72	Saw blade cover bolts M6*16	2
73	Flywheel location flat pad Ø12*Ø35*3	2
74	Saw blade guard handle M8	1
75	Flywheel location locknut M12	1
76	Flywheel tensioning ball thrust bearing 51101	1
77	Saw head lifting bolts	2
78	Saw head frame	1
79	Engine adjust bolts M8*70	1

## **Guarantee**

The warranty period for structural parts of the machine is one year.

Blades, blade guides, brushes, belts, clutch, etc. (wear parts) are not part of the warranty.

## **Loss of warranty**

- Damage resulting from improper installation, operation or maintenance or from items prohibited in the instructions
- Damage caused by repair by yourself without authorization from our company.
- Damage caused by the replacement or addition of other spare parts produced by other manufacturers to this machine without prior permission.
- Damage caused by fire or any natural disaster.



# PART DIAGRAM

